



The OBSERVATORY
on borderless higher education

Global Forum 2009

Global Connections, Local Impacts:
Best Practices, Models & Policies for Cross-Border Higher Education

21-24 October 2009
Kuala Lumpur Malaysia





**Stamenka
Uvalić-Trumbić**



**John
Daniel**

The OBSERVATORY
on borderless higher education

Global Forum 2009
Global Connections, Local Impacts:
Best Practices, Models & Policies for Cross-Border Higher Education

21-24 October 2009
Kuala Lumpur Malaysia

The poster features a large globe graphic with a blue eye-like shape at the top. Below the globe is a cityscape of Kuala Lumpur, Malaysia, including the Petronas Twin Towers. At the bottom, there is a row of logos for the event's partners: The University of Nottingham Malaysia Campus, UNESCO, The Association of Commonwealth Universities, apqn, C.O.L., CDN, POLYCOM, PEARSON eCollege, and USDLA.

Borderless Education

personal experiences

- As students (f2f and distance)
- As managers of HEIs and inter-university bodies
- As international public servants at UNESCO

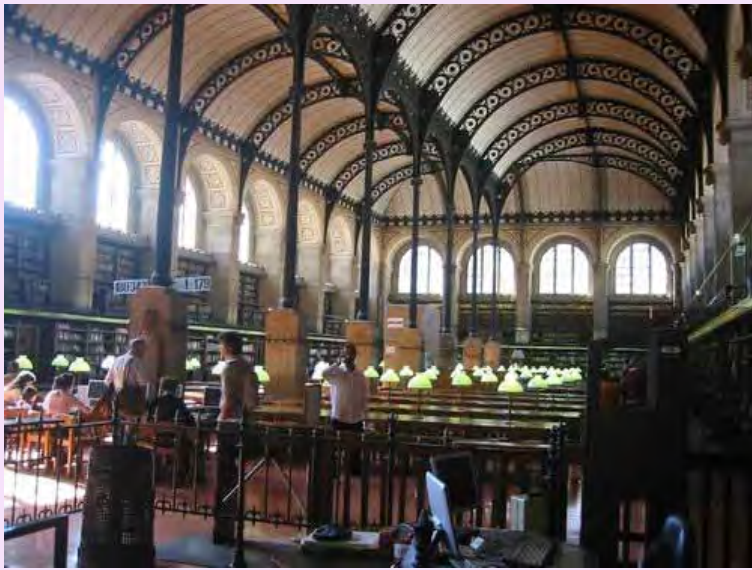

Université de Paris



Yugoslav Universities



CEPES, Bucharest



UNESCO, Paris



Université de Paris



Laurentian University



The Open University

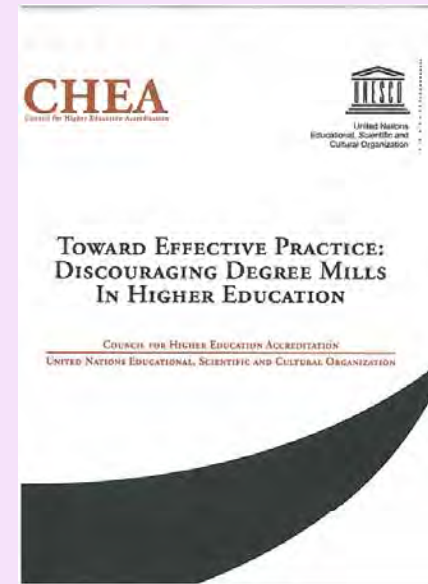

Degree Mills



The OBSERVATORY
on borderless higher education

Global Forum 2009

Global Connections, Local Impacts:
Best Practices, Models & Policies for Cross-Border Higher Education

21-24 October 2009
Kuala Lumpur Malaysia



What is Cross-Border HE?

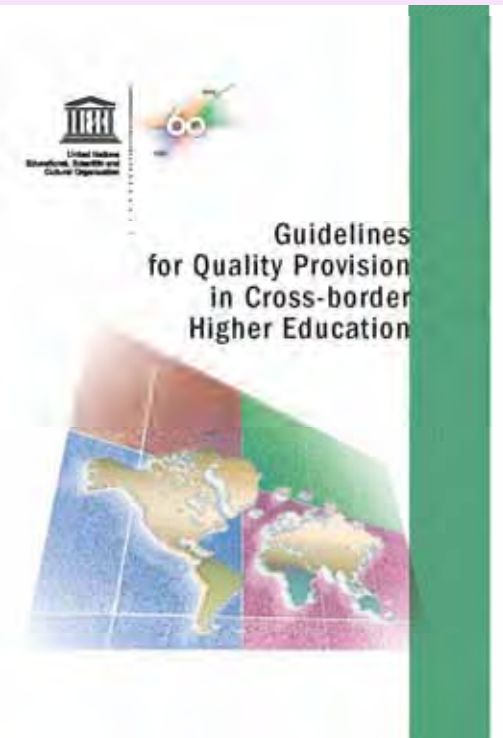

“Cross-border higher education includes higher education that takes place where the teacher, student, programme, institution/provider or course materials cross national jurisdictional borders”



New Delhi

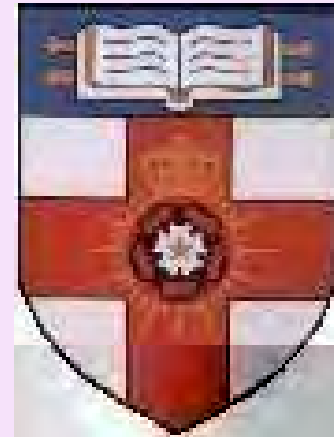

The University of London

University of Paris





Association of Universities of Yugoslavia

IUC



INTER-UNIVERSITY CENTRE DUBROVNIK



Dubrovnik





Kretzulescu Palace, Bucharest

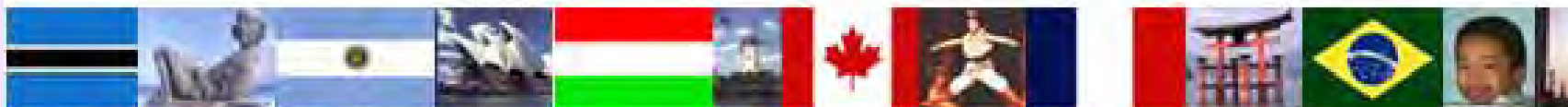

- ① MISSION
- ② HISTORY
- ③ CONFERENCES
- ④ GOVERNING BODIES
- ⑤ CERTIFICATION
- ⑥ NEWSLETTER
- ⑦ PUBLICATIONS
- ⑧ FAQs
- ⑨ INTERNATIONAL ORGANIZATIONS
- ⑩ CONTACT INFO
- ⑪ REQUEST FOR INFO

What is GATE?

The Global Alliance for Transnational Education[®] (GATE[®]) is an international organization concerned with issues relating to quality in Transnational Education (TNE).

GATE has devised a standard of best practices (The Principles for Transnational Education) to which institutions should adhere when offering TNE; it also outlines a process of certification for these institutions that adhere to these Principles.

GATE
8 Winter Street
Suite 508
Boston, MA 02108

E-mail: information@usdla.org

Announcements

Jones International
Transfers GATE to the
United States Distance
Learning Association

[PRESS RELEASE](#)



The Lisbon Convention

Convention on the recognition of qualifications concerning higher education in the european region

(The European Treaty Series, n°165, Council of Europe - UNESCO joint Convention)

Lisbon, 11 April 1997

The Parties to this Convention,

Conscious of the fact that the right to education is a human right, and that higher education, which is instrumental in the pursuit and advancement of knowledge, constitutes an exceptionally rich cultural and scientific

1997

UNESCO and CBHE



Israel, unhappy with the quality of cross-border degrees awarded by UK universities on its territory that its citizens were presenting in expectation of salary increases, asked UNESCO for assistance.



**UNESCO/Council of Europe
Code of Good Practice
in the Provision of Transnational Education
(Riga, 6 June 2001)**

Preamble

The Parties to the Convention on the Recognition of Qualifications concerning Higher Education in the European Region (the Lisbon Recognition Convention),

Conscious of the rapid development of transnational education, characterised by those arrangements and partnerships between institutions and organisations in which the students



7^e Arr.
**PLACE
DE
FONTENOY**
PARIS 7^e Arr. - Fontenoy

UNESCO HQ Paris



**Robin
Middlehurst**

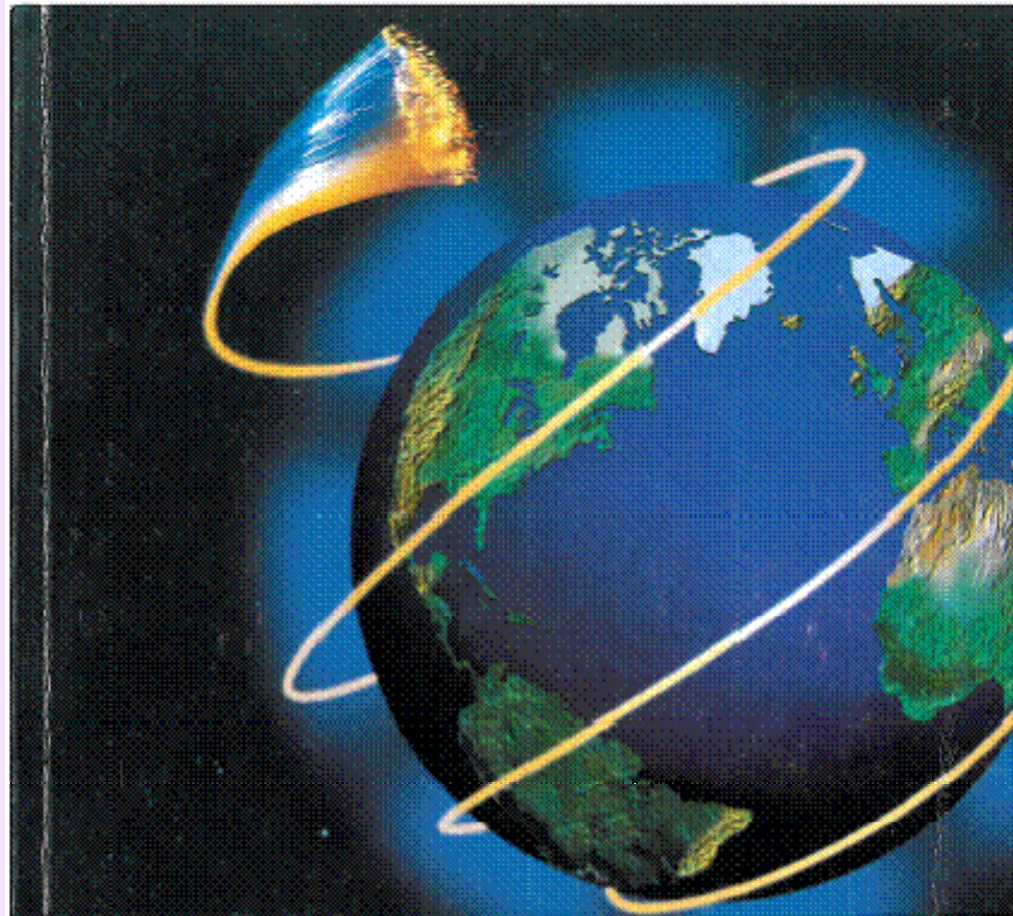

**The Business of Borderless Education:
UK perspectives**

**Analysis and
recommendations**

CVCP
The voice of
UK universities

higher education
hefce
FUNDING COUNCIL FOR HIGHER EDUCATION

UNESCO and CBHE

*Regulation and Legislation regarding
correspondence education:
A survey of five countries with
recommended guidelines for developing
countries*

prepared for UNESCO by
ICCE
(International Council for Correspondence Education)

1978

UNESCO and CBHE



**US/OECD
2002
Forum on
GATS**



***'Trade, Education and the GATS:
What's In, What's Out, What's All the
Fuss About?'***

Pierre Sauvé (OECD)

UNESCO and CBHE

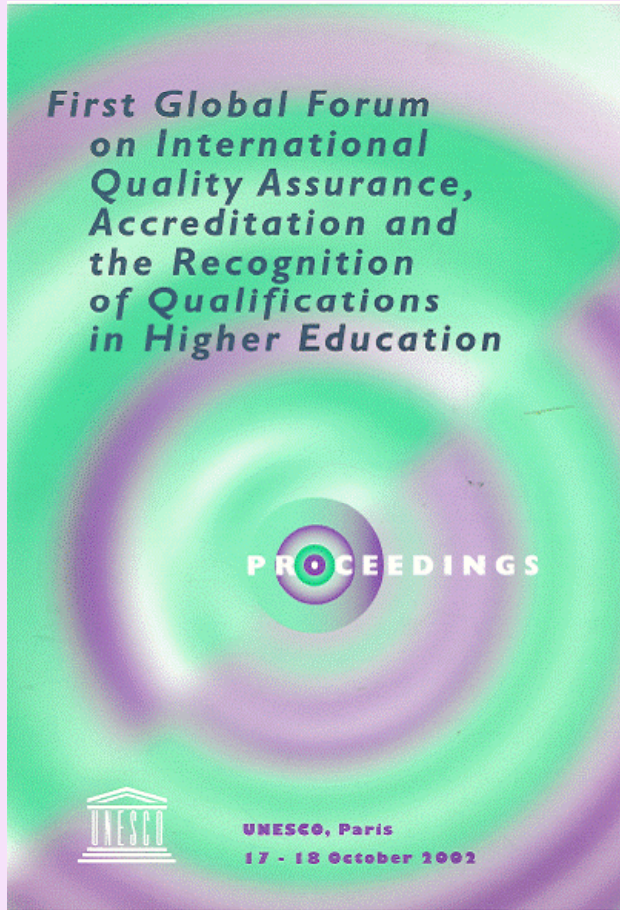

Carolyn Campbell

Rapporteur

2002

OECD and CBHE

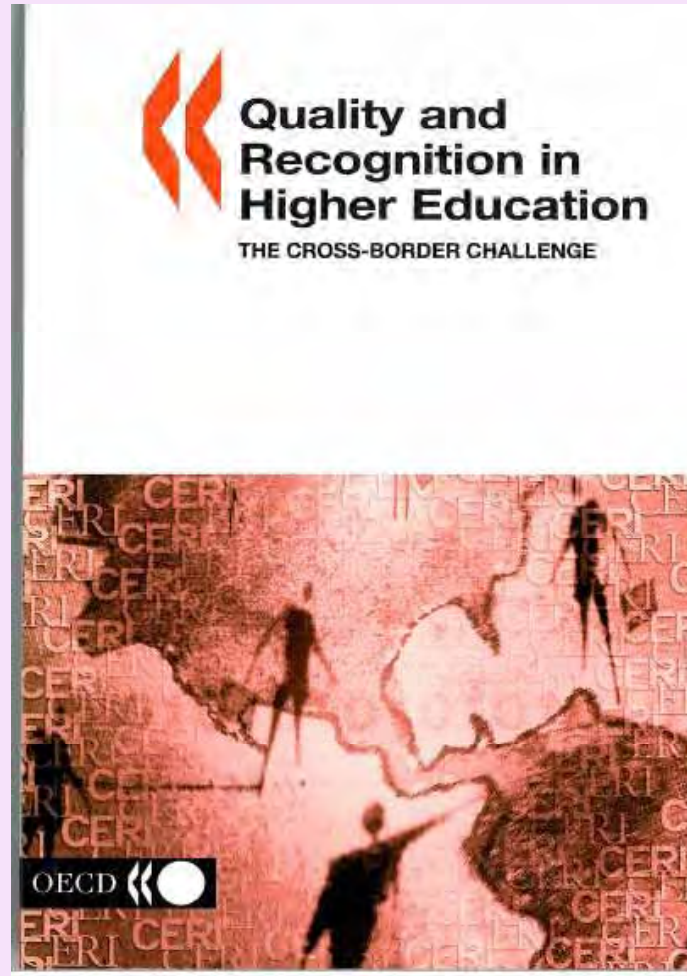

2004

Guidelines for quality provision in cross-border higher education UNESCO and OECD

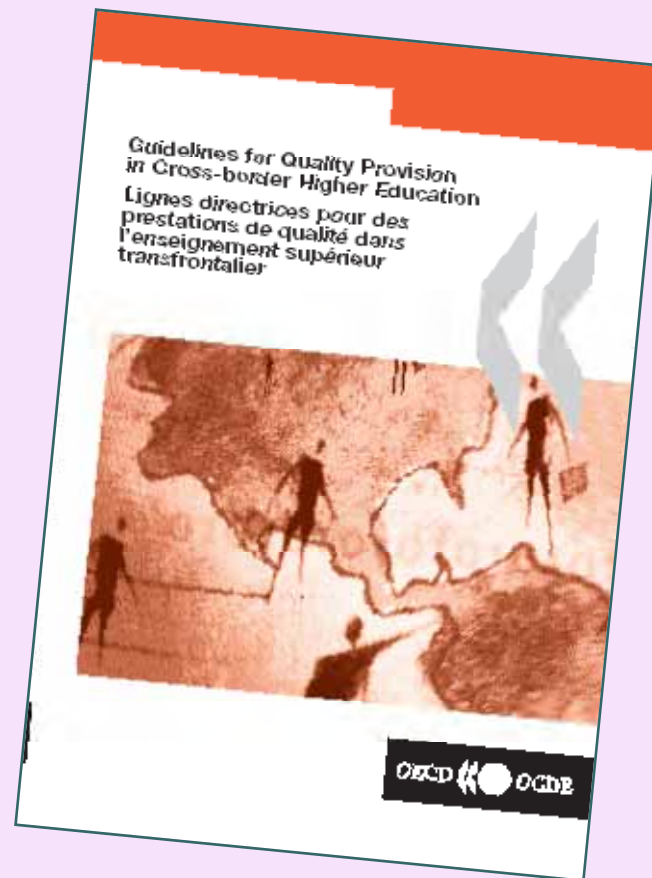
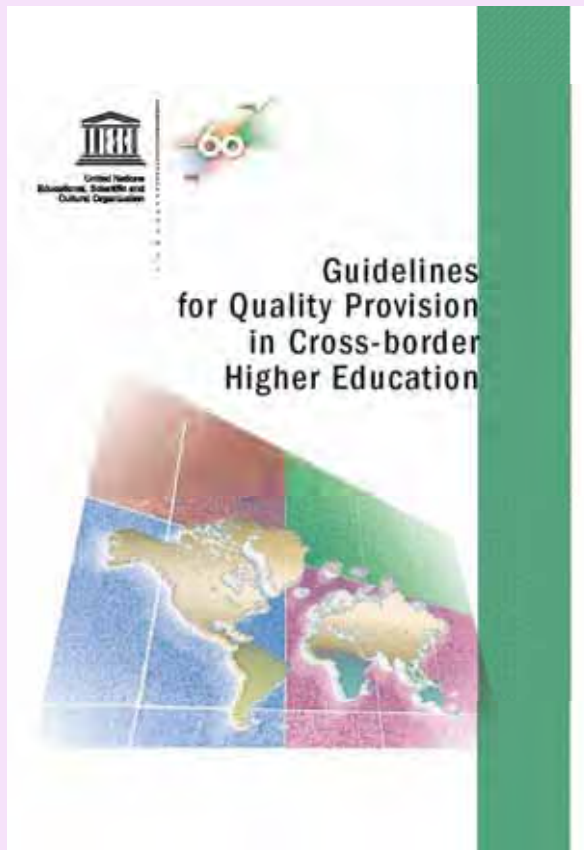



Guidelines
for Quality Provision
in Cross-border
Higher Education

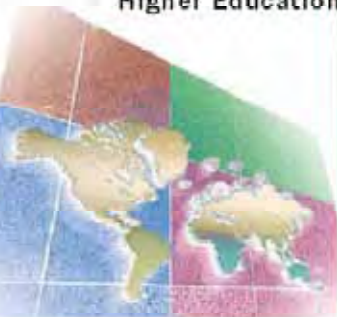

Organisation
des Nations Unies
pour l'Éducation,
la science et la culture



Lignes directrices
pour des prestations
de qualité dans
l'enseignement supérieur
transfrontalier

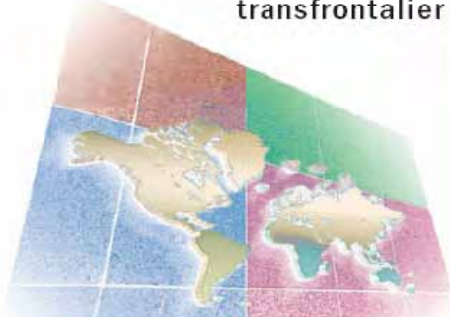

Organisation
des Nations Unies
pour l'Éducation,
la science et la culture



Directrices en materia
de calidad de la educación
superior a través
de las fronteras



Руководящие принципы
для обеспечения
качества в
трансграничном
высшем образовании



منظمة
الأمم المتحدة
للدراسة والعلم
والثقافة

مبادئ توجيهية
بشأن جودة
التعليم العالي
الموفر عبر الحدود



联合国
教育、科学及文化组织



保障跨国界
高等教育办学质量
的指导方针





The Bologna Process 2020 - The European Higher Education Area in the new decade

**Communiqué of the Conference of
European Ministers Responsible for Higher Education,
Leuven and Louvain-la-Neuve, 28-29 April 2009**



benelux
2009

We, the Ministers responsible for higher education in the 46 countries of the Bologna Process convened in Leuven/Louvain-la-Neuve, Belgium, on April 28 and 29, 2009 to take stock of the achievements of the Bologna Process and to establish the priorities for the European Higher Education Area (EHEA) for the next decade.



World
Conference on
Higher Education **2009**

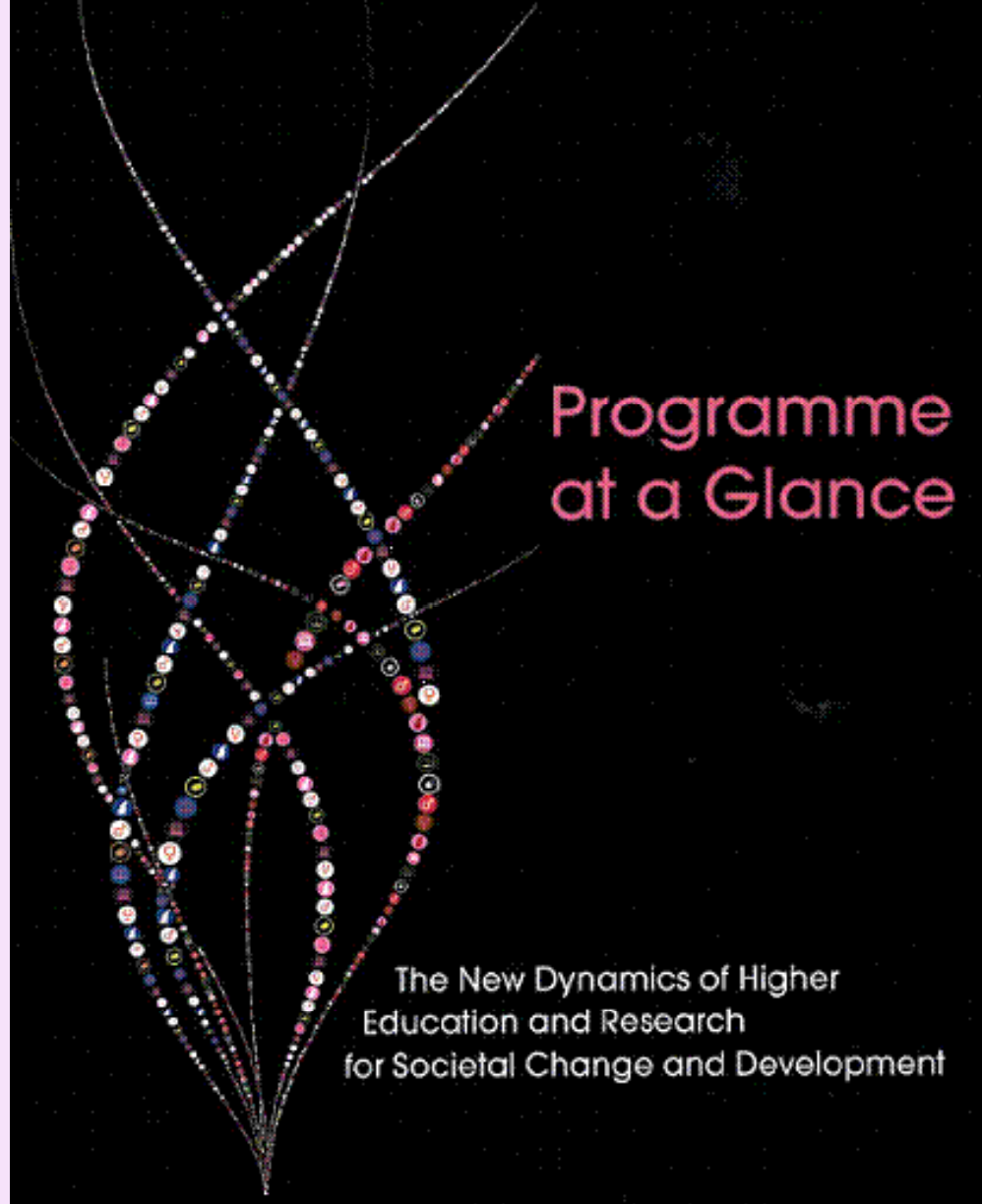

Programme at a Glance

The New Dynamics of Higher
Education and Research
for Societal Change and Development



World Conference on Higher Education
UNESCO, Paris, 5 - 8 July 2009



World
Conference on
Higher Education **2009**



Sonoma State University
The Trustees of
The California State University
on recommendation of the Faculty have conferred upon
Robert W. Baird
the degree of
Bachelor of Science
in Business Administration (Marketing)
with all the rights and privileges pertaining thereto.
Given this twenty-second day of May, two thousand and four.



Donald Schwaninger
Governor of California and President of the Trustees
Charles B. Reed
Speaker of the California State Assembly

Debra S. Faxon
State of the Board of Trustees
Thomas
President of the University



BEWARE



DEGREE MILLS & BOGUS COLLEGES

WHY DEGREE MILLS?

- High demand for Higher Education



WHY DEGREE MILLS?



- More study abroad

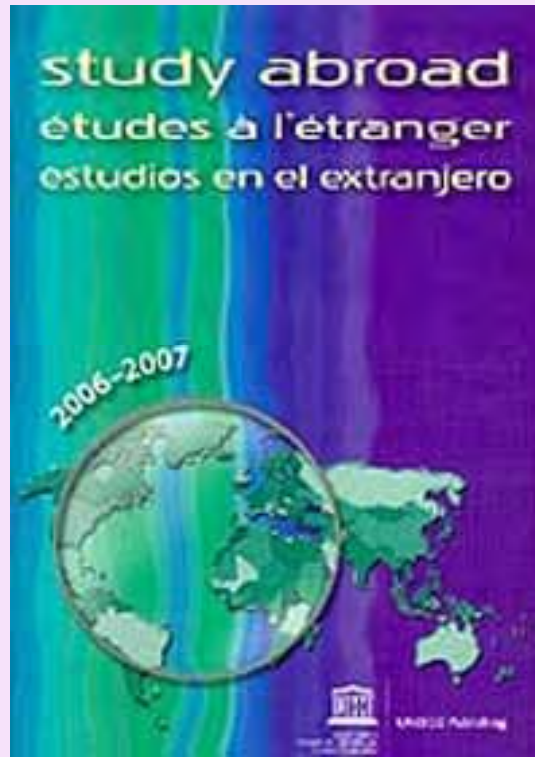

WHY DEGREE MILLS?



- The Internet



Our Campus

Part 1

Intergovernmental organisations:

- Combating degree mills by putting in place structures and processes to support the internationalisation of higher education.
- Helping students find their way around in this new world

Part 2

What can you do about degree mills?

- No magic bullet
- Action on various fronts



UNESCO's work

INTERNATIONALISATION OF QUALITY ASSURANCE:

- Rankings
- Bologna : European Standards and Guidelines
- International and regional networks:
INQAAHE;
ANQAHE; APQN; AfriQUAN; CANQATE;
RIACES

UNESCO's work



GLOBAL OUTREACH THROUGH:

Standard-Setting :

- UNESCO Conventions for the Recognition of Degrees in Higher Education;
- 2005 Guidelines for Quality Provision in CBHE

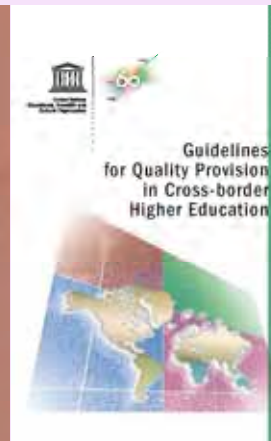

UNESCO's work



GLOBAL OUTREACH THROUGH:

Capacity-Building:

- UNESCO Global Forum on QA, Accreditation and the Recognition of Qualification (2002; 2004; 2007)
- UNESCO-World Bank Global Initiative GIQAC





United Nations
Educational, Scientific and
Cultural Organization

New capacity- building initiative **GIQAC**



- A UNESCO-WB partnership to support capacity-building in developing and transition countries
- Launched in January 2008 for a 3-year period
- Participants 2008: regional QA networks from Africa, Arab States, Asia and the Pacific, Latin America, the Caribbean and the international QA network INQAAHE

UNESCO's work



GLOBAL OUTREACH THROUGH:

Clearinghouse

- Study Abroad
- Portal on HEIs
- Effective International Practices for Degree Mills



What is the Portal on Higher Education Institutions?

- This Portal is a follow up to the UNESCO/OECD Guidelines for Quality Provision in Cross-border Higher Education.
- It targets students, employers, and other interested parties (e.g. credential evaluators).
- It aims to provide students, employers and other interested parties with access to authoritative and up-to-date information on the status of HEIs and QA in participating countries.

Country Information on the Portal

The screenshot shows the UNESCO Portal on Higher Education Institutions for China. The page is titled "UNESCO Portal on Higher Education Institutions" and is for the country of China. It features a navigation menu with categories like Education, Natural Sciences, Social & Human Sciences, Culture, and Communication & Information. The main content area is divided into sections: "List of Countries" (with a dropdown menu set to "China"), "Project", "Resources", and "Themes". The "Project" section includes links for "About us", "Study Abroad", and "Guidelines Cross-border Higher Education". The "Resources" section includes links for "Institutions recognized by competent authorities", "Programmes recognized by competent authorities", "Information for students planning to study in the country", "Information on the higher education system", "Foreign credential assessment and recognition", "Financial assistance opportunities", "Cross-border higher education", and "National information centre". The "Themes" section includes links for "Higher Education and ICTs", "Quality Assurance and Recognition", and "Cross-Border Higher Education". The "National Focal Point" section identifies Mr. Che Weimin as the Director of the Chinese Service Center for Scholarly Exchange (CSCSE), with contact information. The "Definition of 'Recognized Higher Education Institution' in China" is noted as not available. The page also includes two numbered sections: "1. Higher education institutions recognized by competent authorities" and "2. Higher education programmes recognized by competent authorities", each with a list of links to specific information in English and Chinese. A "Back to top" link is provided at the end of each section.

UNESCO.org Education Natural Sciences Social & Human Sciences Culture Communication & Information

United Nations Educational, Scientific and Cultural Organization

EDUCATION

Text Sitemap OK Advanced search English Français Español

UNESCO.org / Education / Higher Education / UNESCO Portal on Higher Education Institutions /

List of Countries UNESCO Portal on Higher Education Institutions

Choose

China

- [Institutions recognized by competent authorities](#)
- [Programmes recognized by competent authorities](#)
- [Information for students planning to study in the country](#)
- [Information on the higher education system](#)
- [Foreign credential assessment and recognition](#)
- [Financial assistance opportunities](#)
- [Cross-border higher education](#)
- [National information centre](#)

This Information has been provided by:

- Ministry of Education of the People's Republic of China.
[English](#) | [Chinese](#)

National Focal Point:

Mr Che Weimin
Director of Division, Chinese Service Center for Scholarly Exchange (CSCSE)
Email: wmche@cscse.edu.cn

Definition of "Recognized Higher Education Institution" in China: Not available

1. Higher education institutions recognized by competent authorities:

- [List of recognized higher education institutions in China](#)
[English](#) | [Chinese](#)
- [List of Chinese Institutions admitting foreign students](#)
[English](#) | [Chinese](#)

[Back to top](#)

2. Higher education programmes recognized by competent authorities:

- [List of Undergraduate Programmes.](#) [Chinese](#)
- [List of Postgraduate Programmes.](#) [Chinese](#)
- [List of China-Foreign Jointly Run Programmes.](#) [Chinese](#)

[Back to top](#)

1. Institutions recognized by competent authorities
2. Higher education programmes recognized by competent authorities
3. Information for students planning to study in the country
4. Information on the higher education system
5. Foreign credential assessment and recognition
6. Information on financial assistance opportunities
7. Cross-border higher education
8. National Information Centre
9. Other information sources
10. Definition of key terms

BEWARE



DEGREE MILLS & BOGUS COLLEGES

Bogus Institutions misusing UNESCO's name

- All levels of abuse and use. The claims may range from 100% false to not quite untrue
- A multitude of modes:
 - Attempt to establish a false connection or misrepresent a link with UNESCO to give the impression of being internationally recognised
 - One institution may use 1-3 different modes
 - Institutions change rapidly



Accreditation

St. Regis is Nationally Chartered (1984) and FULLY ACCREDITED by the Higher Education Commission of the Education Ministry of Liberia, which grants recognition to post-secondary education institutions in Liberia including University of Liberia and Cuttington University College.

The Republic of Liberia is one of the earliest United Nations Educational Organization [UNESCO Higher Education Partners](#), and a historical [American colony](#). St. Regis University is accredited as a degree-awarding post-secondary institution of higher education in the form of a university by the National Commission on Higher Education, the only [Higher Education accrediting authority](#) of the Ministry of Education in the Government of Liberia.



Federal accreditation by a National Government representative college or university, and the validity of awarded academic

'Degree evaluators in the United States and abroad accredited by a nation's Ministry of Education, it is viewed as a nationally recognized degree in other countries.'

St. Regis University is dedicated to meet and often exceed education credentialing in the Distance Education area.

From 'The [Perspective](#)' (Atlanta, Georgia): "Liberian Growth 2003".

For telephone or postal verification accreditation, you may contact:

The Embassy of Liberia
5201 16th Street, N.W.
Washington, DC 20011
(202) 723-0437

www.liberianembassy.com

For telephone or postal verification accreditation, you may contact:

**UNESCO Division of Higher Education
- Tel: (+33.1) 45681106**

➤ Support for UNESCOs framework

➤ Links to UNESCO



Recognizing Excellence

- Home
- Institutions
- Complaints
- Advertisements
- Contributions
- Application
- Contact Us
- UNESCO
- World Health Org.

About EAA

Information, Policies, Requirements, Procedures, and More

This Page is divided into several informative sections. **CLICK** on the section title below, or **SCROLL** down to the desired section. We hope you find this information helpful. Thank you for your interest.

[EAA Code of Ethics](#)

[Accreditation Information](#)

[EAA Mission Statement](#)

[Credentials](#)

[Why Be EAA Accredited](#)

[Sponsor / Contributor Information](#)

[General Information](#)

[Advertiser Information](#)

[Policies](#)

Direct links to UNESCO & World Health Org

EAA and its accredited institutions accept and adopt "The Recommendations of the World Conference on Higher Education, sponsored by UNESCO", and the applicable sections of the "UNESCO Guidelines for Quality Provision in Cross-Border Higher Education"

and encourage
and staff.

stitution or person is discriminated against or de
n, Religion, Economic Status, Class or Social Sta

Require without preference or favoritism, all accredited insti
by the Ethics Code, Accreditation Requirements and

se of; Gender, Race,

knowledge, and abide
institutions.

How do we advance?



Giacometti sculpture – UNESCO Paris

OXFORD



PARIS



a medieval education





Paris, May 1968



A research lab is a great place to learn a language!

je participe
tu participes
il participe
nous participons
vous participerez
ils profitent



LA POLICE



RETOUR
A LA NORMALE...



SOY un MARKISTA
de la tendencia
de GROUCHO



Laurentian University
Sudbury, Ontario
Canada

**Université
canadienne en
France**

Villefranche-sur-mer



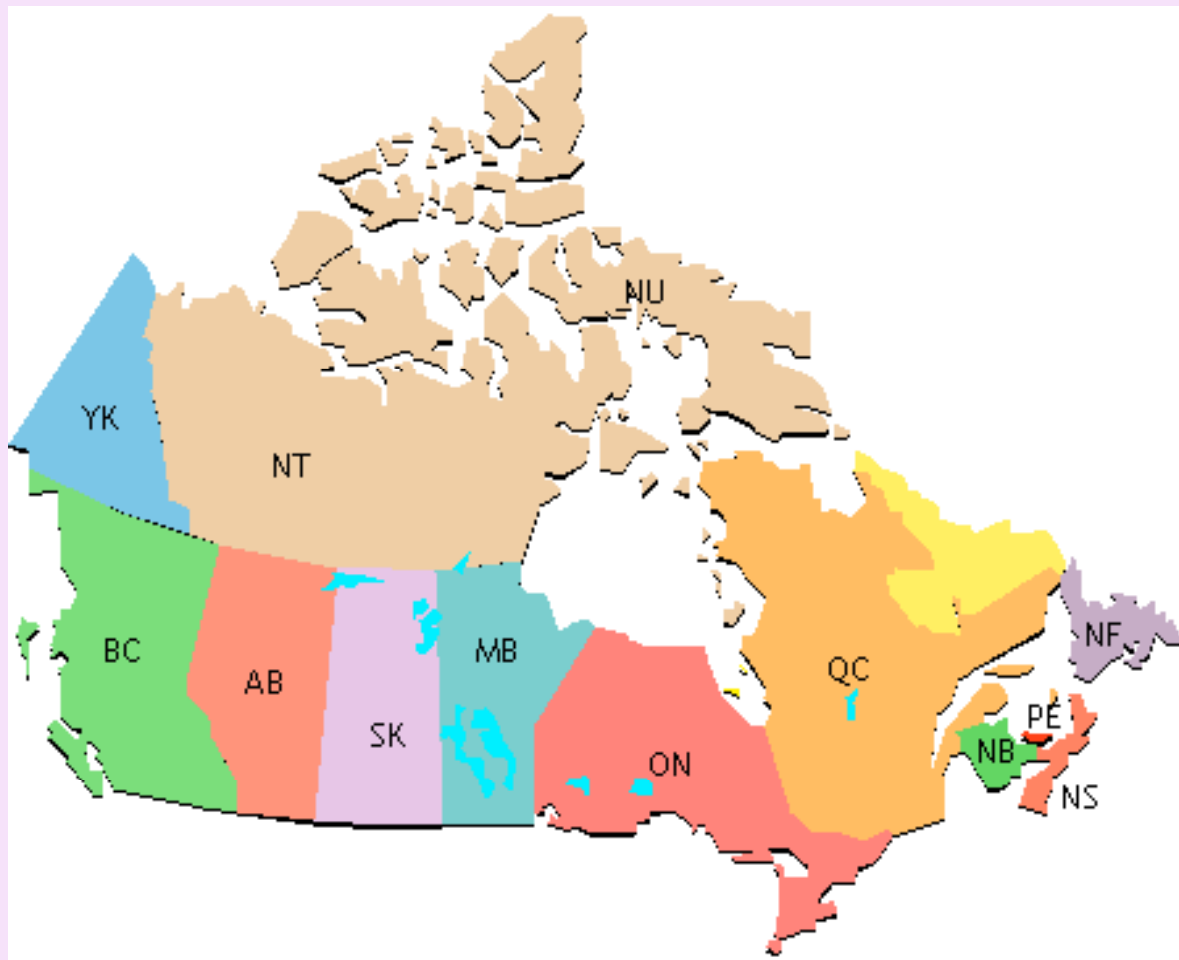

**Students recruited from universities
across Canada**

Campuses abroad

Lessons:

- Don't be timid
- Don't expect it to last forever



Outside the UK:

> 60,000 students (OU awards)

~ 1,000,000 students (local awards with OU courses)



“We seem, as it were, to have conquered and peopled half of the world in a fit of absence of mind”

Sir John Robert Seeley, 1883





The Open University

- Hungary
 - Russia
 - Bulgaria
 - Czech Republic
 - Slovakia
 - Romania
- ~ 10,000 students*





**Meles Zenawi,
Prime Minister of Ethiopia
MBA Graduate with Distinction, UKOU**

Lessons learned:

UKOU borderless programmes:

- Policy development is a challenge

Three Open University Vice-Chancellors



John Daniel
1990-2001

Brenda Gourley
2001-2009

Martin Bean
2009-

Lessons learned:

UKOU borderless programmes:

- Policy development is a challenge
- Develop the partners and make yourself dispensable

OU Business School

People & Partners



Home
Our Different
Approach

Partners

News



Search

[About Us](#) [Programmes](#) [Admissions](#) [Study at UniSIM](#) [Alumni](#) [Upcoming Events](#) [Calendars](#)

[About Us > President's welcome](#)

[PRINT VERSION](#) ▶

[president's welcome](#)

[profile](#)

[board of trustees](#)

[schools](#) ▶

[centre for applied research](#)

[educational technology
& production](#)



OU Business School

People & Partners



[Home](#)
[Our Different Approach](#)

[Partners](#)

[News](#)



OMI - Exkluzivní partner
The Open University Business School
pro Českou a Slovenskou republiku

[Hledat](#)

[Česky](#)

[Slovensky](#)

[English](#)



About us

[Contacts](#)

The truly global business school

[e-mail](#) | [Site map](#) | [web studio](#) | 



New Bulgarian University

Ne varietatem timeamus



» [NBU FOR ALL](#)

» [PROSPECTIVE STUDENTS](#)

» [STUDENTS](#)

» [ALUMNI](#)

» [LECTURERS](#)

» [ADMINISTRATION](#)

Lessons learned:

UKOU borderless programmes:

- Policy development is a challenge
- Develop the partners and make yourself dispensable
- Partnerships are good in principle and effective in practice



UKOU + OUHK = a winning partnership



COMMONWEALTH *of* LEARNING



The Virtual University for Small States of the Commonwealth

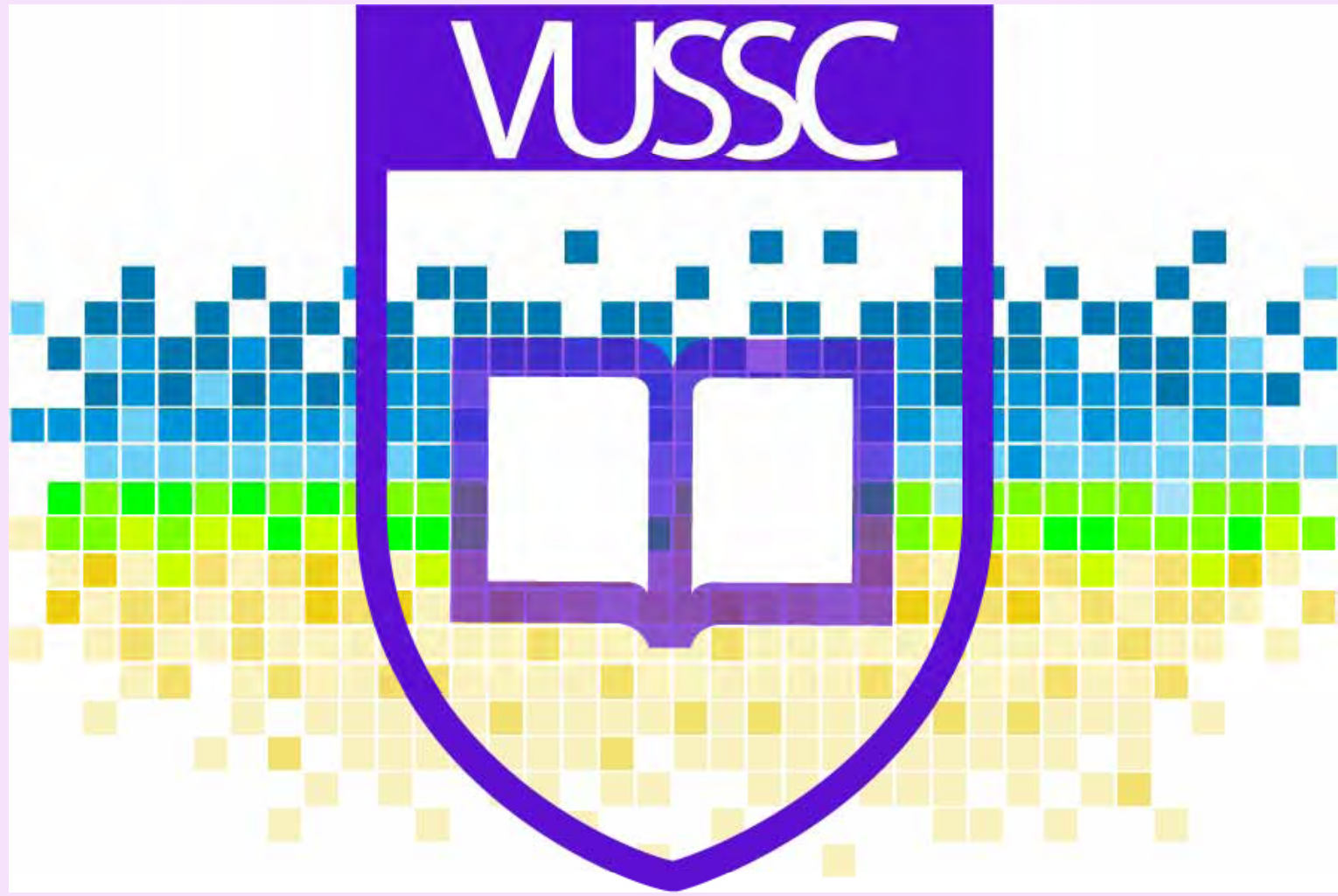

CHEA
Council for Higher Education Accreditation



**TOWARD EFFECTIVE PRACTICE:
DISCOURAGING DEGREE MILLS
IN HIGHER EDUCATION**

COUNCIL FOR HIGHER EDUCATION ACCREDITATION
UNITED NATIONS EDUCATIONAL, SCIENTIFIC AND CULTURAL ORGANIZATION

UNESCO and the Council on Higher Education Accreditation (CHEA) developed suggestions for effective practice on degree mills through an expert group

UNESCO and COL are alerting developing countries and small states to the threat of degree mills

The UNESCO Portal is one response

Detecting Degree Mills

Filter Statements



- Does not have legal authority to award degrees in its home jurisdiction.
- Requires little attendance, either in classrooms or online.
- Requires little, if any, coursework or assignments.
- Limits its contact information to a phone number or an e-mail address.
- Makes false claims about external quality assurance or accreditation.

Detecting Degree Mills

Filter Statements



- Issues degrees that are not accepted for licensing or graduate admission in the home jurisdiction.
- Does not provide verifiable faculty lists, or lists faculty with credentials from degree mills.
- Features websites that copy or imitate material from legitimate organisations.
- Have websites with internet domain registration obscured by a privacy service.

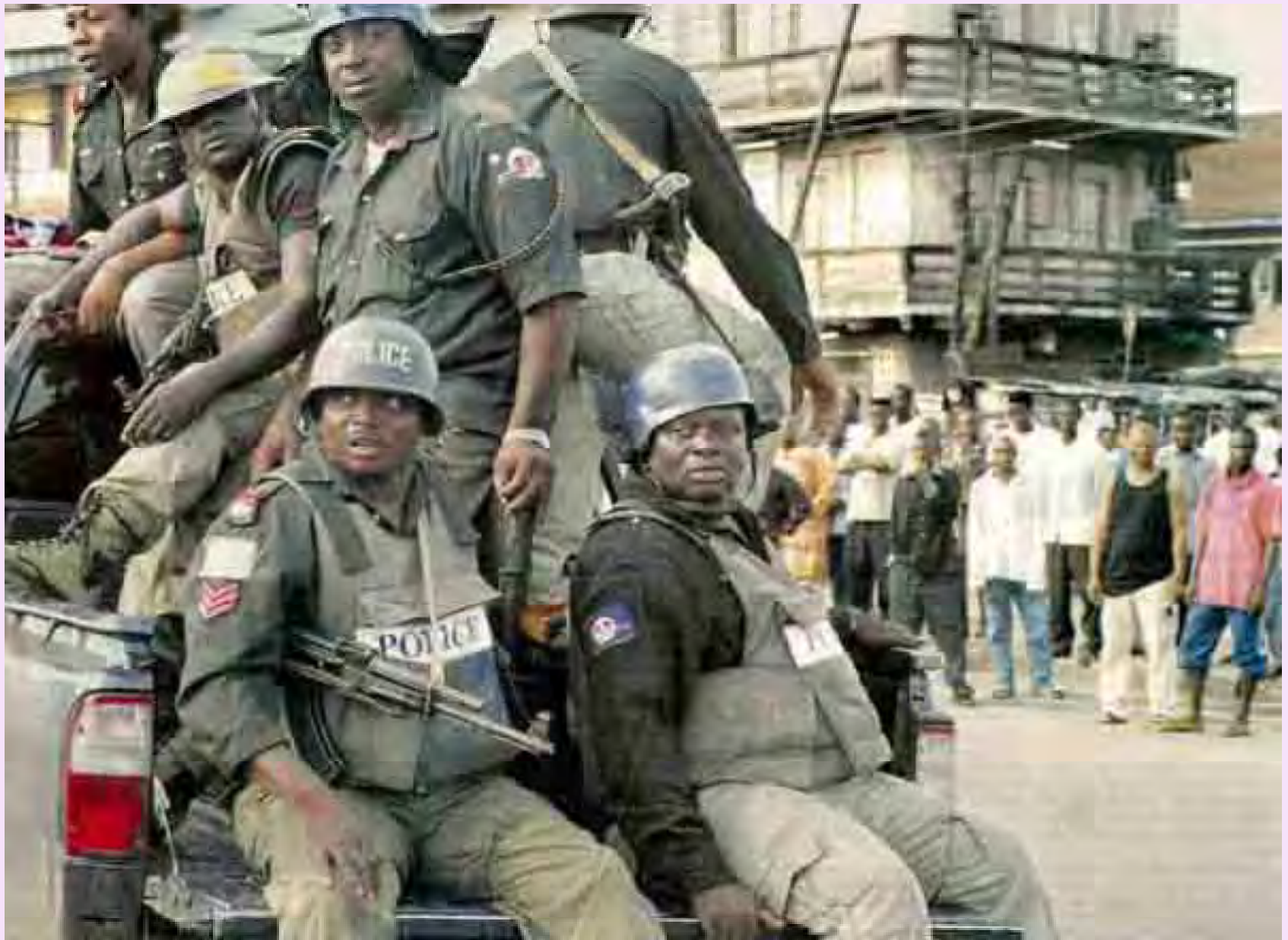

Closing down degree mills in Nigeria!

STEP 1: BUYER BEWARE!

“Help students become savvy consumers and research their options”

Consult STUDY ABROAD

and

UNESCO's portal of white lists:

<http://tinyurl.com/RecognizedHE>

<http://tinyurl.com/RecognisedHE>



STEP 2: GOVERNMENTS

must want to protect the integrity of their
higher education systems...



COAL + IRON ORE + HIGHER EDUCATION = \$\$

STEP 2: GOVERNMENTS

must want to protect the integrity of their higher education systems...

PROTECT TERMS LIKE:

- * University
- * Accreditation



STEP 2: GOVERNMENTS

must want to protect the integrity of their higher education systems...



STEP 3: TRANSPARENT PROCESSES

Quality assurance systems

- List of accredited/recognised institutions and put on UNESCO portal;
- Raise quality of HEIs generally;
- Qualifications frameworks.

STEP 4: AVOID FUNDING DEGREE MILLS OR THEIR STUDENTS



STEP 5:CHECK CREDENTIALS

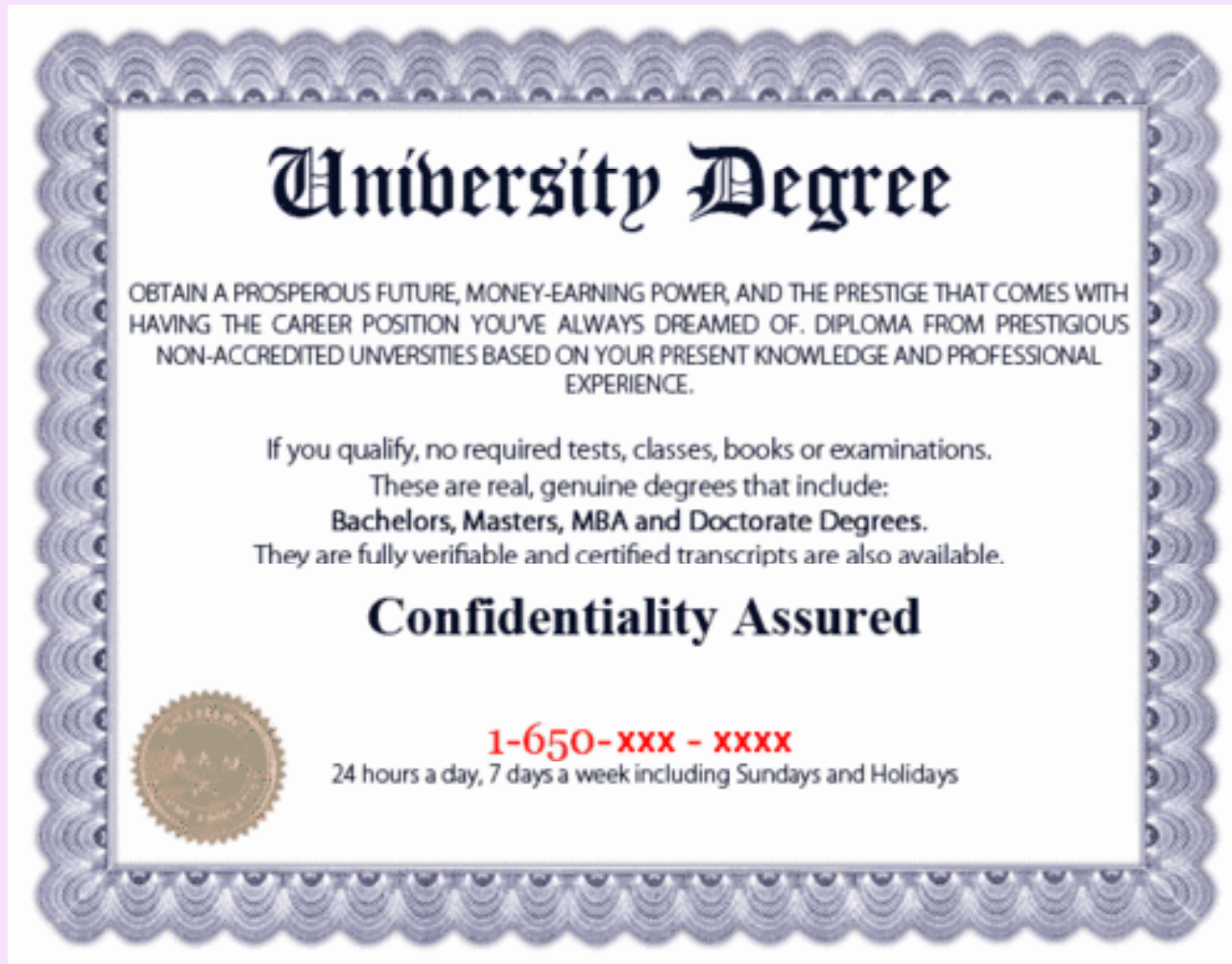

University Degree

OBTAIN A PROSPEROUS FUTURE, MONEY-EARNING POWER, AND THE PRESTIGE THAT COMES WITH HAVING THE CAREER POSITION YOU'VE ALWAYS DREAMED OF. DIPLOMA FROM PRESTIGIOUS NON-ACCREDITED UNIVERSITIES BASED ON YOUR PRESENT KNOWLEDGE AND PROFESSIONAL EXPERIENCE.

If you qualify, no required tests, classes, books or examinations.
These are real, genuine degrees that include:
Bachelors, Masters, MBA and Doctorate Degrees.
They are fully verifiable and certified transcripts are also available.

Confidentiality Assured

1-650-xxx - xxxx
24 hours a day, 7 days a week including Sundays and Holidays



200,000 phony credentials sold annually in the USA

STEP 5:CHECK CREDENTIALS



200,000 phony credentials sold annually in the USA

STEP 5: CHECK CREDENTIALS

PUBLIC KEY CRYPTOGRAPHY

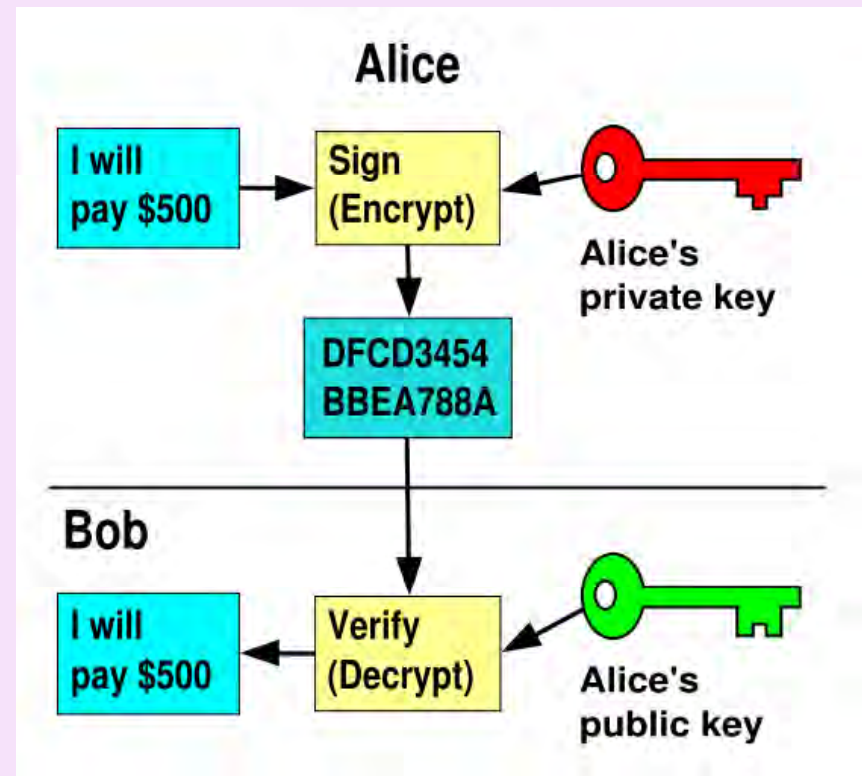
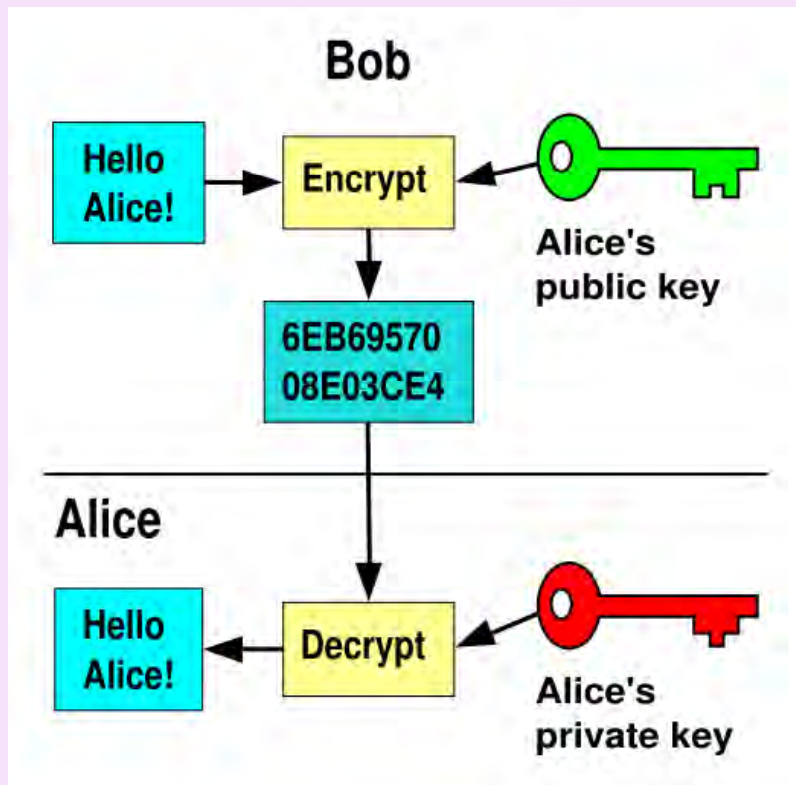

STEP 6: INTERGOVERNMENTAL BODIES



STEP 6: INTERGOVERNMENTAL BODIES



The Doctor of Medicine (M.D.) program at the Medical University of the Americas is recognized by the World Health Organization and listed in the latest World Directory of Medical Schools.



Our Campus

STEP 7: INFORMAL SYSTEM OF ALERTS AND BLACK LISTS

Informal because:

- Vexatious litigation
- Degree mills like chameleons



BEWARE



DEGREE MILLS & BOGUS COLLEGES



The OBSERVATORY
on borderless higher education

Global Forum 2009

Global Connections, Local Impacts:
Best Practices, Models & Policies for Cross-Border Higher Education

21-24 October 2009
Kuala Lumpur Malaysia





**Stamenka
Uvalić-Trumbić**



**John
Daniel**



Thank you

