

BLOCKCHAIN ENABLED E-LEARNING DELIVERY MODEL FOR ENHANCED QUALITY LEARNING

Vincent Omollo Nyangaresi¹ & Dr. Slivance Abeka²

¹Kisii University

²Jaramogi Oginga Odinga University of Science and Technology

Abstract: - Blockchain technology has attracted the attention of the public owing to its numerous strengths such as security, faster transactions, reduced costs, anonymity and data integrity. The success of Bitcoin has led to the adoption of this blockchain technology in many areas such as financial market, IOT, supply chain, voting, medical treatment and storage. Faster transactions are attributed to smart contracts, which represent automated execution of transactions where terms of the transactions are entrenched in computer code that are automatically fulfilled by the software upon acknowledgement of a particular input. A shared ledger contributes to cost savings since it operates without a trusted third party, hence eliminating intermediaries. Despite the success of the blockchain technology in the financial sector, there exists scanty information on how this technology can be utilized in delivering or securing learning materials so as to improve the quality of education materials delivered over the e-learning platforms. This research paper sought to develop a model based on the Funnel e-learning model that unraveled how the blockchain technology can boost quality of education and lifelong learning. It is expected that the implementation of the developed model in learning institutions can help boost the quality of learning over the electronic learning platforms, which is in line with the sustainable development goals.

Keywords: *E-learning, quality education, Modeling, Blockchains, sustainable development, cryptography.*

I. INTRODUCTION

Education is not only a basic human right but also a key element of sustainable development. As such, it is the premise of the United Nations' fourth Sustainable Development Goal that endeavors to ensure inclusive and equitable quality education and promote lifelong learning opportunities for all. Based on this, countries across the globe endeavor to provide quality education, which is characterized by factors such as teacher qualifications, duration students spend in school, student to teacher ratio, government budget on education and test scores (Rehaf, 2019). Quality education involves learners, learning environments, content, process, and outcomes. To increase quality, teachers need to master instructional methods and be able to carry out proper student evaluation and assessment. It is also important that traditional lesson delivery styles be reformed to boost quality learning reflected in the improvement of students' cognitive skills, beliefs, attitudes and knowledge levels. This is particularly crucial since parents regard educational outcome as the most significant measure of quality.

As Elda and Mary (2014) points out, quality formative assessment tools, sufficient materials, appropriate curriculum and pedagogy, sufficient quality teachers, and sufficient time in class greatly contribute to quality education. Quality teaching includes effective design of curriculum and course content, soliciting and using feedback, and effective assessment of learning outcomes. Internet Society (2017) point out that the growth of the internet can greatly enhance the quality of education by facilitating access to a wealth of knowledge, information, educational resources, increasing opportunities for learning in and beyond the classroom. It also enables educational administrators minimize costs and enhance the quality of schools and colleges. This has seen innovations such as e-learning, Open educational resources (OER) and Massive Online Open Courses (MOOCs) crop up and have managed to bypass intellectual property constraints, making course materials available for students across the globe. In so doing, they have supplemented local educational resources, extending the range and quality of materials available to learners. Online education exists in many types including personal skills improvement, vocational training, language education, early childhood education, examination and certification training. Many universities have set up online learning platforms that offer online courses. More specifically, MOOCs represent high quality teaching programs and independent management systems.

In their paper, Vaishali and Dayanand (2015) explain that e-learning involves the application of information technology in the teaching and learning process. It is the usage of computers or electronic devices such as mobile phones to provide training, educational or learning materials. There exist various e-learning models such as demand-driven model, strategic e-learning model, e-learning acceptance model, instructional design model, e-learning life-cycle model, and Laurillard's conversational model. These models serve to describe areas where technology can play specific roles in supporting the learning process. A recent technology capable of disrupting online education system is the Blockchain, a data structure consisting of blocks of data arranged in some chronological order. Blockchain has salient features such as trustworthiness, decentralization, data sharing and security that has rendered this technology applicable in smart contracts (SC), digital currency, and credit card encryption (Carmen, 2018). Recently, the rise in Internet technology has led to online education, an area where blockchain technology can also be implemented to boost its quality.

Our main contribution is the development of a novel extended Funnel model based on the blockchain technology to help alleviate e-learning quality problems. The rest of the paper is organized as follows: Section II, provides a review of the e-learning models while section III discusses the blockchain technology. Section IV to VIII discusses on related work, research problem, research approach, methodology, results and discussion respectively. Section IX concludes the paper and gives future directions in this area.

II. E-LEARNING MODELS

A number of e-learning models that describe where technology plays a precise role in supporting learning have been developed and they include demand-driven model, strategic e-learning model, e-learning acceptance model, instructional design model, e-learning life-cycle model, and Laurillard's conversational model (Vaishali and Dayanand, 2015) as discussed in Table 1.

Table 1: E-Learning Models Descriptions

E-learning Model	Description
Demand-Driven	Based on technology learning management system, contents and services where technology is regarded as a tool to achieve the desired learning outcomes in the most cost-effective way. This model's main aim is to encourage the active participation in the development and use of technology in teaching process (Vaishali and Dayanand, 2015).
Strategic e-Learning	Views students as active, self-determined individuals who process information and construct knowledge. It has the learner at its core, and around this core are three interactive components that determine successful learning: skill, will, and self-regulation (Mohamed and 2014). This model serves as a diagnostic tool for e-learning researchers, system designers, curriculum developers and instructors to evaluate students' e-learning strategies in their experiment, design and development.
E-learning Acceptance	This constitutes of E-learning Technology Acceptance Model and Unified theory of acceptance and use of technology (UTAUT) models. The former model is based on user requirements and is significant in the implementation of e-learning technology. It postulates that user acceptance is the basic determinant of successful implementation of e-learning and that both students' perception of E-learning usage and its perceived usefulness affect their intention (Venkatesh and Davis, 2000). It consists of three variables: perceived ease of use, perceived usefulness, and intention to use. This model focuses on the use of E-learning technology for content management but ignores the following: pedagogical aspects of E-learning, planned implementation of E-learning system, governance and curriculum design, which are the basis of a fully-fledged E-learning system. In addition, the model is incomplete due to its limitation to user interface or technology usability only. On its part, UTAUT's goal is to explain user intentions to utilize an information system and subsequent usage behavior. It holds that performance expectancy, effort expectancy, social influence are direct determinants of usage intention and behavior, and facilitating conditions are direct determinants of use behavior. On the other hand, gender, age, experience, and voluntariness of use moderate the impact of the four key constructs on usage intention and behavior.
Instructional Design	Consists of Gagne's Nine Events of Instruction model and ADDIE model (Analysis, Design, Development, Implementation, and Evaluation). The first model focuses on learning outcomes and how to arrange specific instructional events to achieve those outcomes. The second model represents a dynamic, flexible guideline for building

	effective training and performance support tools. As Fayed et al., (2006) point out, the ADDIE model has numerous flaws that have led to a number of spinoffs or variations such as rapid prototyping which tries to catch problems while they are still easy to fix, and hence save time and money.
E-learning Life-cycle	This model aims to identify critical points for evaluation of e-learning and has six overlapping phases: review, planning, course design, course development, teaching and student learning. In addition, there are drivers and controls that represent those forces which place parameters and restrictions on what can be done.
Laurillards Conversational	This model focuses on student learning and the characteristics of the design, development and delivery that ensure an effective course. However, the model is entirely on the learning and lacks business models needed to ensure the effective delivery of the course around such issues as marketing, recruitment or student support.
Funnel Model for implementing e-learning	Provides a solution for the problems of implementing E-learning in tertiary education institutions (Mohamed and Oso, 2014). Although models such as TAM, theory-based E-learning and pedagogical model have been utilized over time, they are generally inadequate since they treat materials development, instructional design, technology, delivery and governance as separate and isolated entities. The Funnel model enhances all these into one and applies synchronously and asynchronously to E-learning implementation, with the only difference being modalities. It prevents ad-ad-hoc approach which has rendered other systems unused or inefficient, and compromised educational quality. Funnel model should help tertiary education institutions adopt and develop effective and efficient E-learning system which meets users' needs.

Despite the fact that e-learning offers a number of strengths such as reduced costs, ability to log or track learning activities, possibility of continuous monitoring and correction, global collaboration and connectivity among learners, and ability to personalize the training for each learner, this mode of learning faces a number of challenges as discussed in section VI.

III. BLOCKCHAIN TECHNOLOGY

The blockchain (BC) consist of a sequence of blocks holding a complete list of transaction records arranged in a chronological order, just like a conventional public ledger as shown in Figure 1 below (Lee, 2015). Each block points to the immediately previous block through a reference consisting of hash value of the previous block called parent block.

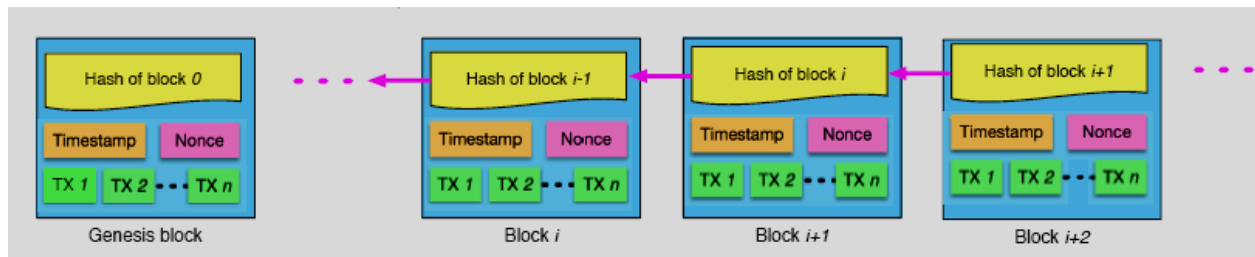

Figure 1: Blockchain Structure

Since the first block has no parent block, it becomes the genesis block. Figure 2 shows that each of these blocks is made up of the block header and the block body. The block header consists of the block version, parent block hash, Merkle tree root hash, timestamp, nBits and nonce. In the block header, parent block hash is a 256-bit hash value that points to the previous block, the block version indicates the set of block validation rules to be followed, Merkle tree root hash is the hash value of all the transactions in the block, timestamp is the present timestamp in seconds since 1970-01-01T00:00 UTC, nBits is the present hashing target in a compact format, while nonce is a 4-byte field that normally begins with 0 and is incremented for every hash calculation.

Block Version	03400000
Parent Block Hash	fgbftghdvc456mj189thn57mx42sdtptz Klnnbvge45nbx78m4gbxt42ds s78jftg
Merkle Tree Root	8jgb45tb6bnb3mj2gb4gbv546gdxcv5 56hvirtwn67mvz53cv5fre2n90ftypokh
Timestamp	36f98a54
nBits	37v47d29
Nonce	Gr7g0963
Transaction Counter	
<div style="display: flex; justify-content: space-around; align-items: center;"> <div style="background-color: #4a7ebb; color: white; padding: 5px 10px; border-radius: 3px;">TX₁</div> <div style="background-color: #4a7ebb; color: white; padding: 5px 10px; border-radius: 3px;">TX₂</div> <div style="flex-grow: 1; text-align: center;">.....</div> <div style="background-color: #4a7ebb; color: white; padding: 5px 10px; border-radius: 3px;">TX_n</div> </div>	

Figure 2: Block Contents

On the other hand, the block body consists of a transaction counter and transactions and the highest number of transactions that a block can hold depends on the block size and the size of each transaction. In terms of cryptography, a digital signature based on asymmetric cryptography is utilized in untrustworthy environment to validate transactions as shown in Figure 3.

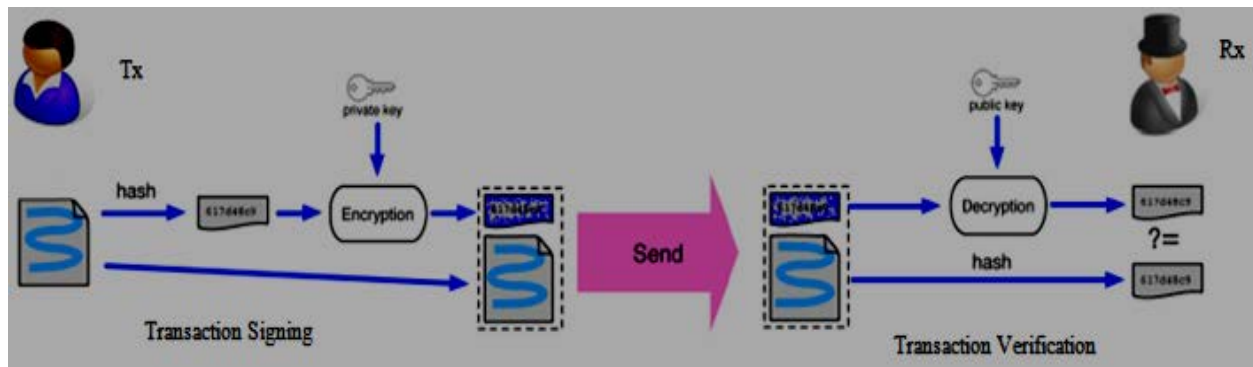

Figure 3: Blockchain Digital Signature

As shown in Figure 3, each user has a pair of private key and public key and the private key is used to sign the transactions. The digitally signed transactions can be accessed across the entire network using public keys visible to everyone in the network. Essentially, the digital signature is employed in two phases: the signing phase and the verification phase.

When T_x wants to sign a transaction, a hash value derived from the transaction is first generated and encrypted using the private key. The encrypted hash with the original data are then sent to another R_x who verifies the received transaction through the comparison between the decrypted hash (by using T_x 's public key) and the hash value derived from the received data by the same hash function as T_x 's. Normally, elliptic curve digital signature algorithm (ECDSA) is the digital signature algorithm employed in BCs. According to Zhenget al., (2018), BC has attractive features such as persistency, decentralization, immutability, trustworthiness, data sharing, security, anonymity and auditability as summarized in Table 2.

This renders BC applicable in fields ranging from financial services, smart contracts, crypto-currency, reputation systems, public services, security services, risk management, internet of things (IoT) to public and social services.

Table 2: Blockchain Technology Features & Significance

Feature	Significance
Decentralization	Eliminates chances of data loss on the entire network due to attacks on a single node. Trust between distributed nodes is built through mathematical methods rather than centralized institutions
Immutable	All transactions are stored in blocks with one hash key linking from the previous block and one hash key pointing to the next block and hence tampering with any transaction results into different hash values and would hence be detected by all the other nodes running exactly similar validation algorithm
Sharable	Is a shareable public ledger stored on thousands of node and all ledgers continue to synchronize in real time, hence successful tampering would need to change over 51% of the ledgers stored in the network. Whenever a new ledger transaction takes place, the block of the transaction data is recorded and linked to the chain via ECDSA by the entire system and as such, data cannot be falsified or forged. In addition, the transaction data is broadcasted across the network and confirmed by all network nodes, making them undeletable (Tschorsch and Scheuermann, 2016).

In their study, Grech, A., & Camilleri (2017) point out that the strengths of BC include self-sovereignty, trust, transparency and provenance, immutability, disintermediation, and collaboration as illustrated in Table 3.

Table 3: Blockchain Strengths

Strength	Description
Self-sovereignty	Users identify themselves and maintain control over the storage and management of their personal data.
Trust	Technical infrastructure offers secure operations such as payments or issue of certificates.
Transparency and provenance	Transactions are performed with the knowledge that each party is able to enter into that transaction.
Immutability	Records are written and stored permanently without the prospect of modifications.
Disintermediation	There is no need for a central controlling authority to manage transactions or keep records.
Collaboration	Parties transact directly with each other without the need for third-parties.

There is a need to harness these strengths in an e-learning environment so that some of the challenges in the current online education platforms can be addressed as discussed in section VI.

IV. RELATED WORK

In their paper, Guanget al., (2018) investigated BC and its potential educational applications as well as the problems it could solve in this field. A study by Sharples and Domingue (2016) has also focused on how BC technology can be applied in education. In his paper, Carmen (2018), BC is proposed for proof of learning, management of credentials and transcripts, management of student records, management of reputation, and payments. Sony Global Education has implemented BC-based project to maintain and manage transcripts and high security data, such as learning history (Hoy, 2017). According to Skiba (2017), the author explains that some universities and institutes have applied BC technology in education to support academic degree management and summative evaluation for learning outcomes such as formulating transcripts.

Regarding informal learning, BC can safely store information about research experience, skills, online learning experience as well as individual interests (Guang et al., 2018). The University of Nicosia employs this technology to manage students' certificates received from MOOC platforms (Sharples and Domingue, 2016). The authors propose BC for the realization of knowledge currency, a kind of distributed storage of education data. Massachusetts

Institute of Technology (MIT) and the Learning Machine company have cooperated to design a digital badge for online learning based on BC in which students receive certification which is stored on a BC network (Skiba, 2017). A study by Antonio et al., (2017) established that BC can prove the elements of a resume prepared by someone without storing the data in a center vulnerable to attacks or violations of its integrity, hence preventing the alteration of data scattered across a distributed system.

Moiz et al., (2018) proposed a learner model for adaptable e-learning model based on the findings of a survey conducted to investigate the profiles and preferences of the local learners. This model was shown to have a significant impact on the performance of students. Aithal and Shubhrajyotsna(2017) presented an Ideal Education System model by considering its various characteristics under Input conditions, Systems requirements, Output conditions and Environmental and social conditions. That authors claimed their model could prepare students for the working world and prepare them to become empowered to transform the working world to better suit the needs of the people. In ideal Education system, students take exams any time, any number of times and results are declared immediately and it therefore satisfies its students’ intellectual needs. Kennedy et al., (2017) presented a model for evaluating Learning Management System (LMS) assisted e-learning through reviewing existing e-learning frameworks and models for quality evaluation. However, this model was not evaluated.

V. RESEARCH PROBLEM

The current e-learning systems face a number of challenges such as course development, purchase, student record keeping, credentials verification, intellectual property protection and poor student experience, all of which reduces the quality of education offered in these platforms. Despite the fact that the blockchain technology can help address some of these problems, no model has been developed to demonstrate how this technology can blend with e-learning to improve the quality of education.

VI. RESEARCH APPROACH

To boost the quality of e-learning based education, there is need for the learning process and results to be trustable, which necessitate the development of a distributed and trustable data storage method that discloses all learning data to the public, records students’ learning process, and ensure student data security. Due to the lifelong nature of current education, the transcript should also not be closed archive but a continuous record of achievements to which teachers, tutors and other experts may add throughout a learner’s lifetime.

BC can bind together these diverse credential records (blocks) into a chronological order (chain). For the learning institutions, this is a way of minimizing administrative costs and bureaucratic procedures while boosting security in the maintenance of student records. BC technology has the potential to solve e-learning problems such as lack of recognition, data insecurity and poor certification. This is significant in that personal encrypted credentials facilitates the shaping of lifelong learning pathways and personalizes education based on individual values and requirements. In addition, it permits the permanent documentation of both formal and informal learning based on transversal competencies, adjustable across the economic sector and responsive to situational needs. Table 4 gives a summary of the e-learning challenges as well as what this research paper proposes as the possible solution.

Table 4: E-learning Challenges and Proposed Solutions

Challenges	Proposed Solution
Course development, assessment, learner support, institutional factors, user characteristics and overall performance.	BC & SC
Learning process and results of MOOCs fall short of public recognition and official certification.	BC
Compromises students’ privacy since courses and data security entirely depends on the centralized online education platform.	BC
Students’ intellectual property cannot be maintained effectively due to the openness of the Internet	BC
No mature cross-platform course sharing mechanism to fully share the teaching resources due to the constraints such as education mode and copyright.	BC & SC
Current paper transcript is too limited because it misses a number of items that can give a full picture of the student’s achievements and potential such as mastery level, extra-curricular activities	BC & SC

contributing to the student's development such as voluntary service, description of the skills achieved, internships and study abroad, and personal factors such as creativity, motivation or leadership potential.	
Learners are faced with difficulties in directly accessing their credentials since they depend on third parties such as universities and former employees	BC
The transcript verification process is slow	BC
The growing demand for skills update is rendering learning lifelong which calls for permanent, verified documentation. These educational trends represent the holistic goals of Education for Sustainable Development (ESD) The current BC-based learning facilitates movement of students between institutions and the transfer of reliable information to employers. Unfortunately, no progress has been made in the warranty of contents such as skills and abilities, whose validation remains centralized in institutions with a reputation ratified by national or transnational authorities.	BC & SC
Evaluation is a problem in the education system and although formative assessment has been advocated for a long time, it is still not ripe because it is not easy to track every detail of teaching and learning.	BC & SC
There is poor user experience for students learning different types of courses as they have to log into different platforms.	BC & SC
It is cumbersome for students to study the knowledge in another school or discipline and hence many quality course resources are wasted due to absence of unified and efficient utilization.	BC & SC

A review of related work in e-learning models and frameworks for quality has shown that there are a number of factors not accounted for by the existing frameworks and models of e-learning. In this paper, a model that encompasses all stages in the e-learning process is proposed. This model will help address challenges of e-learning technology such as course credibility, credit and certificate certification, student privacy, and course sharing. This will involve the usage of blockchain technology to store learning records in a trusted and distributed manner, provide credible digital certificates, realize efficiency in learning resource sharing with smart contract (SC), and protect intellectual property through data encryption. To effectively achieve ESD, there is need for learners to collect competencies and achievements garnered lifelong in an environment that is secure, transparent, and permanent with direct user access. Blockchain and smart contracts can greatly help facilitate these requirements.

VII. METHODOLOGY

This paper adopted a positivist research philosophy and used descriptive design to achieve its objectives. The issuance of a BC secured educational credentials will involve five sequential phases as shown in Figure 4. The process begins by the creation of a digital file containing some basic information such as the name of the university and student, issue date and the credential. The second step is the cryptographic signing of the certificate content by the university, using a private key accessible only to the university.

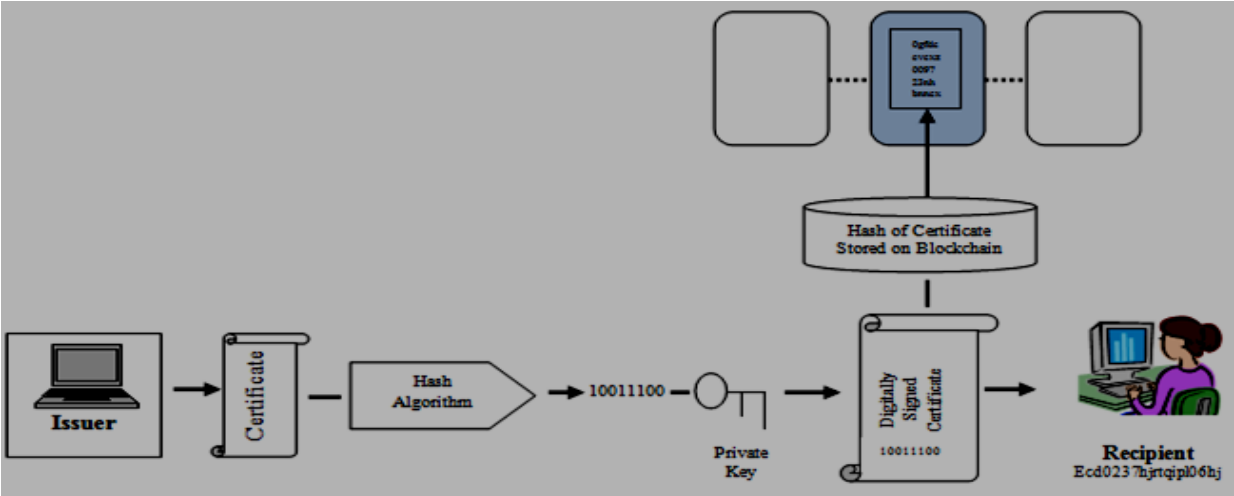

Figure 4: Issuing a Blockchain Secured Certificate

During the third phase, the university appends that signature to the certificate itself. The fourth step involves the university creating a cryptographic hash of the credential file that is used to validate the integrity of the content of the certificate. Lastly, the university employs its private key again to create a record on the BC that states it issued a certain certificate to a certain student on a certain date.

A review of the various e-learning models revealed that the Funnel model is superior and hence is the model that this paper extended. It is designed to solve the mismatches between curriculum design of E-learning and its delivery while the models have either focused only on usability, pedagogy or on technology. For instance, TAM and Theory-Based Models do not have governance and finance, materials development and instructional design which are key in any educational endeavor. It is flexible, adaptable, and applicable to all institutions and to all concepts since it is requirement driven. In its original form, the Funnel model appears as shown in Figure 5. This required that teaching and learning materials be put in place and delivery mode designed.

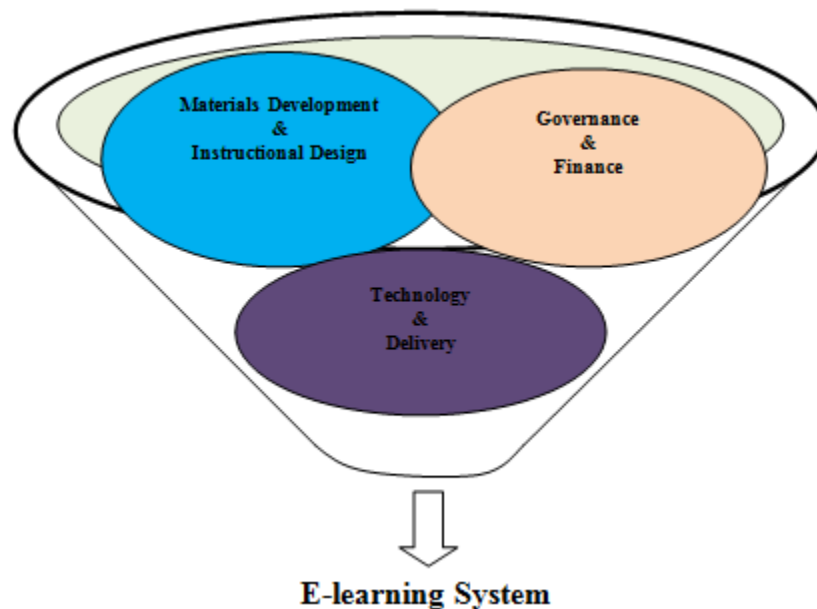

Figure 5: Funnel Model for E-learning Implementation

As shown in Figure 5, the model consists of three coordinated components necessary for the establishment of demand based E-learning system: materials development and instructional design; role of governance and finance; and as well as functions and responsibilities of technology and delivery.

In this model, technology is a tool for conveying content to the learners which means that the technological design can be either synchronous or asynchronous. To ensure that technology matches instructional design of the teaching materials, this model pays attention to usability and availability of technology. Since sustainability of any system depends on its management, the model incorporates administration in form of governance and finance. This model will be extended by use of BC technology as shown in Figure 6. As shown in this figure, the BC technology was hypothesized to have influence on e-learning technology and delivery. The BC technology features that were hypothesized to influence materials development and instructional design included direct user access, traceability and immutability. These three characteristics were thought to facilitate nine (9) e-learning activities including course sharing, course purchase, peer to peer networking, ranking of tutors, single sign on, learner motivation, constructivism instructions, research supervision, and program fragmentation.

On the other hand, BC features such as direct user access, transparency, immutability, credibility, reliability, traceability, trustworthy, authenticity and integrity were thought to facilitate proof of learning, credential and transmit management, students record management, reputation management, learning outcomes evaluation, verification of credentials, tuition payment and intellectual property (IP) protection. All these eight (8) activities were hypothesized to influence e-learning governance and finance.

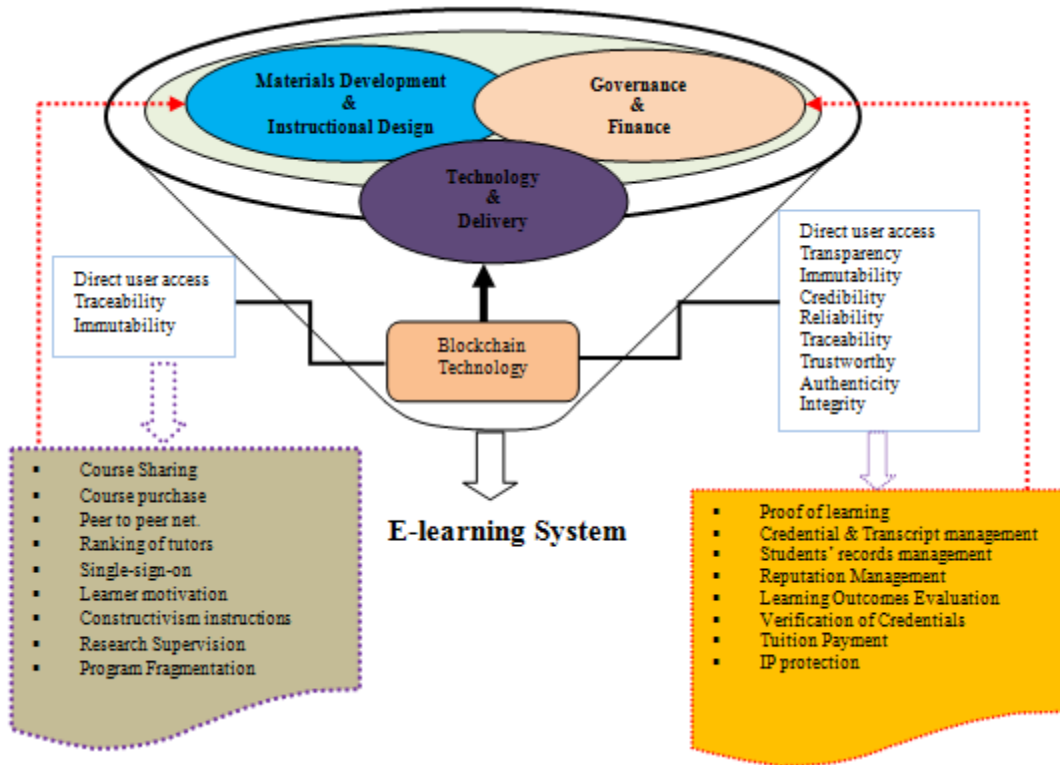

Figure 6: Proposed Extended Funnel Model for e-learning Implementation

The e-learning quality evaluation was carried out using E-learning Quality evaluation framework (EQF) which bases its evaluation on seven factors: faculty support factors, technological factors, student support factors, institutional factors, pedagogical factors, instructional design factors and course evaluation factors as shown in Figure 7.

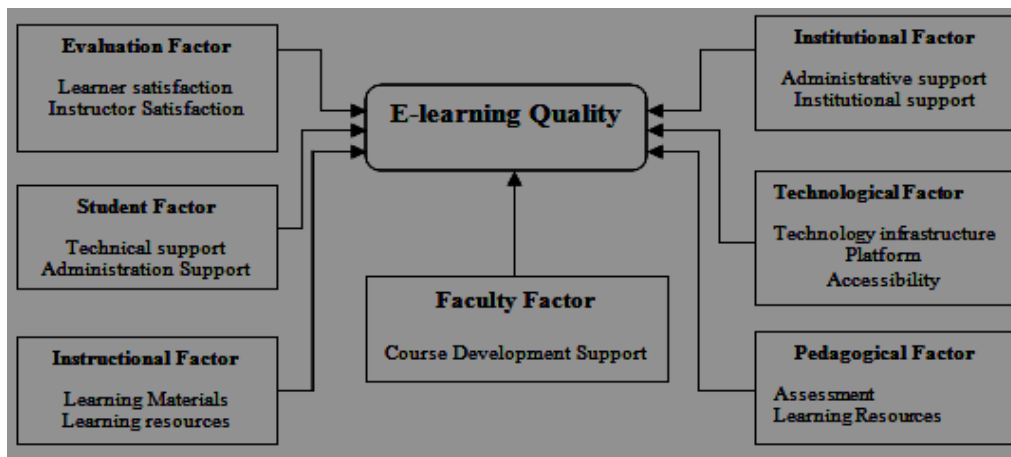

Figure 7: E-learning Quality Framework

For model evaluation, two levels of validation were carried out. The first one took BC technology (BCT) as the latent variable while its features (direct user access-DUA, traceability-TRC, Immutability-IMM, Transparency-TRP, credibility-CRB, Reliability-RLB Trustworthy-TWT, Authenticity-ATC, Integrity-INT) as constructs as shown in Figure 8. The second validation had two latent variables: materials development and instruction design (MDID); and governance and finance (GF) as shown in Figure 9. The predictors for MDID included Course sharing-CSR, Course purchase-CPE, Peer to peer networking-P2P, Ranking of tutors-ROT, Single sign on-SSO, Learner motivation-LMT, Constructivism instructions-CIN, Research supervision-RSP, and Program Fragmentation-PFR.

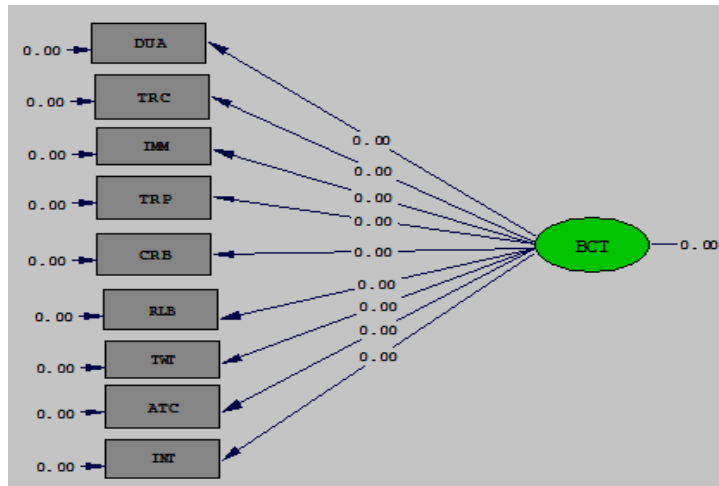

Figure 8: Blockchain Hypothesized Predictors

The predictors of GF included Proof of learning-PLN, Credentials and transcript management-CTM, Students records management-RMG, Reputation management-RPM, Learning outcomes management-LOM, Verification of credentials-VOC, Tuition payment-TPT, and IP protection-IPP.

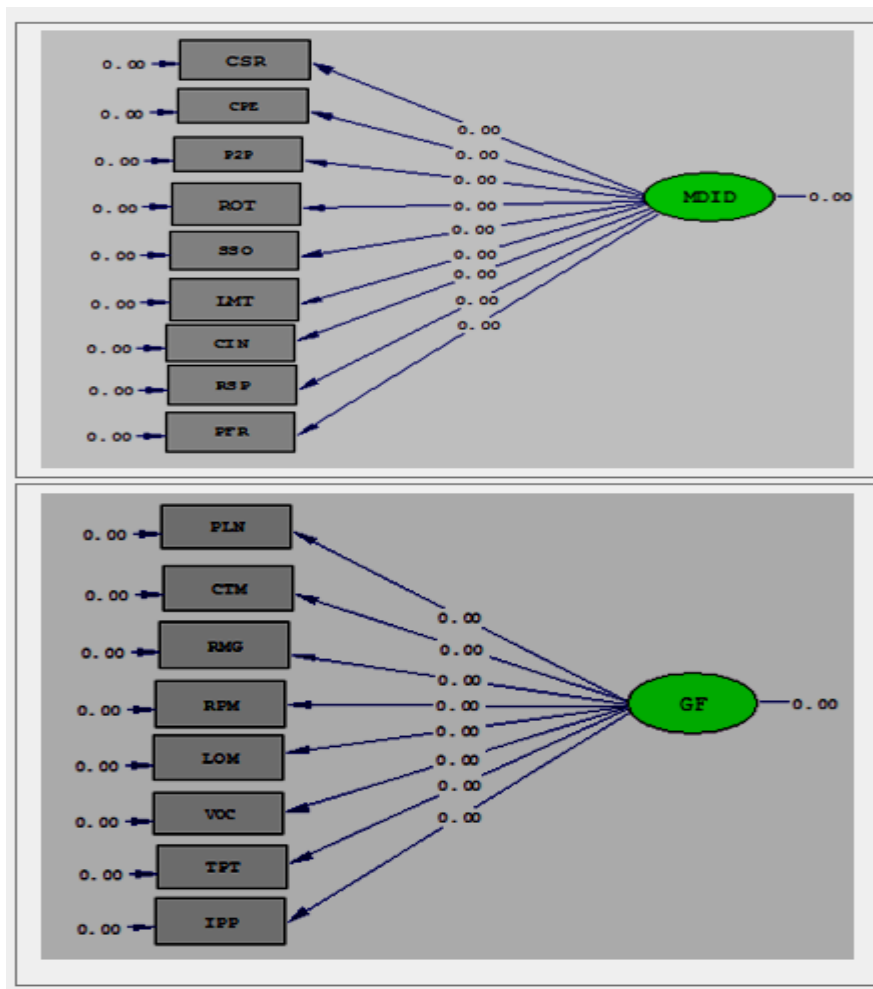

Figure 9: MDID and GF Predictors

The items used in the extended funnel model of e-learning implementation are briefly explained in Table 5. Some of these items were based on the E-learning Quality evaluation framework (EQF) while others were derived from the blockchain characteristics.

Table 5: E-Learning Quality Factors

Quality Factor	E-learning context
Credibility	BC facilitates support of real degrees with virtual copy of degrees and other credentials. BC storage protects integrity and reliability of these credentials due to timestamps that ensure traceability
Credit Transfer	BC enabled smart contracts between institutions on credit transfer agreements. Upon fulfillment of certain conditions, credits are automatically transferred
Educational material copyrighting	BC permit publication of content openly, while keeping track of re-use, without putting limitation on the source material.
Payment & Funding	Fees can be paid through crypto-currency
Peer to peer networking	BC support tutor-student peer to peer network with direct connections in terms of interaction and payment. Enable students to rank tutors based on quality of materials they offer. This encourages tutors to improve their quality
Student Records Management	BC records data in chronological order by timestamps, new data block cannot be deleted. Cryptographic algorithm prevents data tampering hence reduces fraud. Decentralization enables learning trajectories can be recorded across regions and time
Reliability	Ensured by encryption technology
Credentials Verification	Learning data of the student are recorded on the BC. Encrypted certificates are issued to students and other recipients on the network. Employers can perform hash verification of the digital certificates using the public key of the platform or university, hence prevent paper fraud, fake academic credentials
Certification of learning Results	BC provides simple, efficient solution to certify learning results, and enable students obtain a copy of lost certificate
Sharing of educational resources	Smart contract (program system developed on cryptographic security system) can complete sophisticated operations without human intervention. It supports automatic execution and verification, hence can facilitate sharing of e-learning materials online
Course purchase & payment	Enabled by smart contracts
Single sign on	Distributed nature of BC permits students access to different platforms' resources by logging into only one node in the BC network. Global knowledge systems such as academic journals and Wikipedia can be added to the BC network to form global knowledge base, greatly improving learning efficiency and quality
Integrity, authenticity	It is possible to verify that the certificate was originally issued by and received by the same persons indicated in the certificate(integrity); there is confidence that the issuer is who the certificate claims, and has not been forged (authenticity)
Immutability, trustworthy	Learning data are matched with student' ID and stored in BC which are then checked, validated, and maintained by the miners from all over the world, reducing degree fraud.
Learner motivation	Smart contracts based on BC can be employed to motivate learners in real-time in form of digital currency through some simple clicks by the tutors.
Constructivism instruction	Collaborative learning cultivates students 'ability to work with others. However, it is currently marred with free -riding, hampering fair evaluation. With BC, this can be prevented by having each student submit work through unique accounts in the learning platform. Smart contracts running on the platform review student performance and records results into blocks.
Ranking of tutors	Tutors first submit pre-planned instructional activities as smart contracts to schools and during the teaching process, all teaching activities are recorded in the BC network. As an evaluation criterion, smart contract verifies consistency of the teaching design and practice. Tutors who meet standards get digital currency as a reward and this serves as an encouragement for tutor's teaching skills.
Research supervision	All supervision activities can be monitored by smart contract and recorded into the BC ledger to protect the interest of both student and supervisor.
Program fragmentation	Curriculum model corresponds to program fragmentation into small blocks of reading activities, units and lessons that students run based on their needs and skills. Each unit is translated into a smart contract that is resolved when the student acquires satisfactory knowledge and skills.

Confirmatory factor analysis was used to evaluate convergent validity, internal reliability and model fit. Specifically, the model fit was established using structured equation modeling (SEM) through Lisrel software. The internal consistency reliability was measured using Cronbach's alpha.

VIII. RESULTS AND DISCUSSION

The first part of the analysis was confirmatory factor analysis, whose results indicated that all reliability coefficients were higher than 0.7 as shown in Table 6. As such the questionnaire items had good internal consistency.

Table 6: Reliability Coefficients

Blockchain Item-Total Statistics				
	Scale Mean if Item Deleted	Scale Variance if Item Deleted	Corrected Item-Total Correlation	Cronbach's Alpha if Item Deleted
Direct User Access	33.14	10.858	.770	.897
Traceability	32.88	12.598	.659	.905
Immutability	33.14	10.858	.770	.897
Transparency	32.88	12.598	.659	.905
Credibility	33.14	10.858	.770	.897
Reliability	32.88	12.598	.659	.905
Trustworthy	33.14	10.858	.770	.897
Authenticity	32.88	12.598	.659	.905
Integrity	32.88	12.598	.659	.905

MDID Item-Total Statistics				
	Scale Mean if Item Deleted	Scale Variance if Item Deleted	Corrected Item-Total Correlation	Cronbach's Alpha if Item Deleted
Course Sharing	33.20	9.673	.749	.867
Course Purchase	32.96	11.468	.597	.881
Peer To Peer Networking	33.16	9.974	.668	.875
Ranking Of Tutors	32.94	11.364	.614	.880
Single Sign On	33.22	9.767	.746	.867
Learner Motivation	32.92	11.218	.647	.877
Constructivism Instructions	33.20	9.755	.727	.869
Research supervision	32.90	11.439	.551	.883
Program Fragmentation	32.94	11.486	.568	.882

GF Item-Total Statistics				
	Scale Mean if Item Deleted	Scale Variance if Item Deleted	Corrected Item-Total Correlation	Cronbach's Alpha if Item Deleted
Proof Of Learning	29.16	8.096	.796	.833
Credentials & Transcript Management	28.98	10.510	.455	.870
Students Records Management	29.14	8.368	.739	.840
Reputation Management	28.94	10.343	.484	.868
Learning Outcomes Management	29.18	8.191	.787	.834
Verification Of Credentials	28.92	10.198	.523	.865
Tuition Payment	29.18	8.273	.763	.837
IP Protection	28.90	10.378	.445	.871

Regarding convergent validity the research constructs, some of the, loaded higher than the threshold value of 0.5 while others loaded below this value as shown in Figure 10.

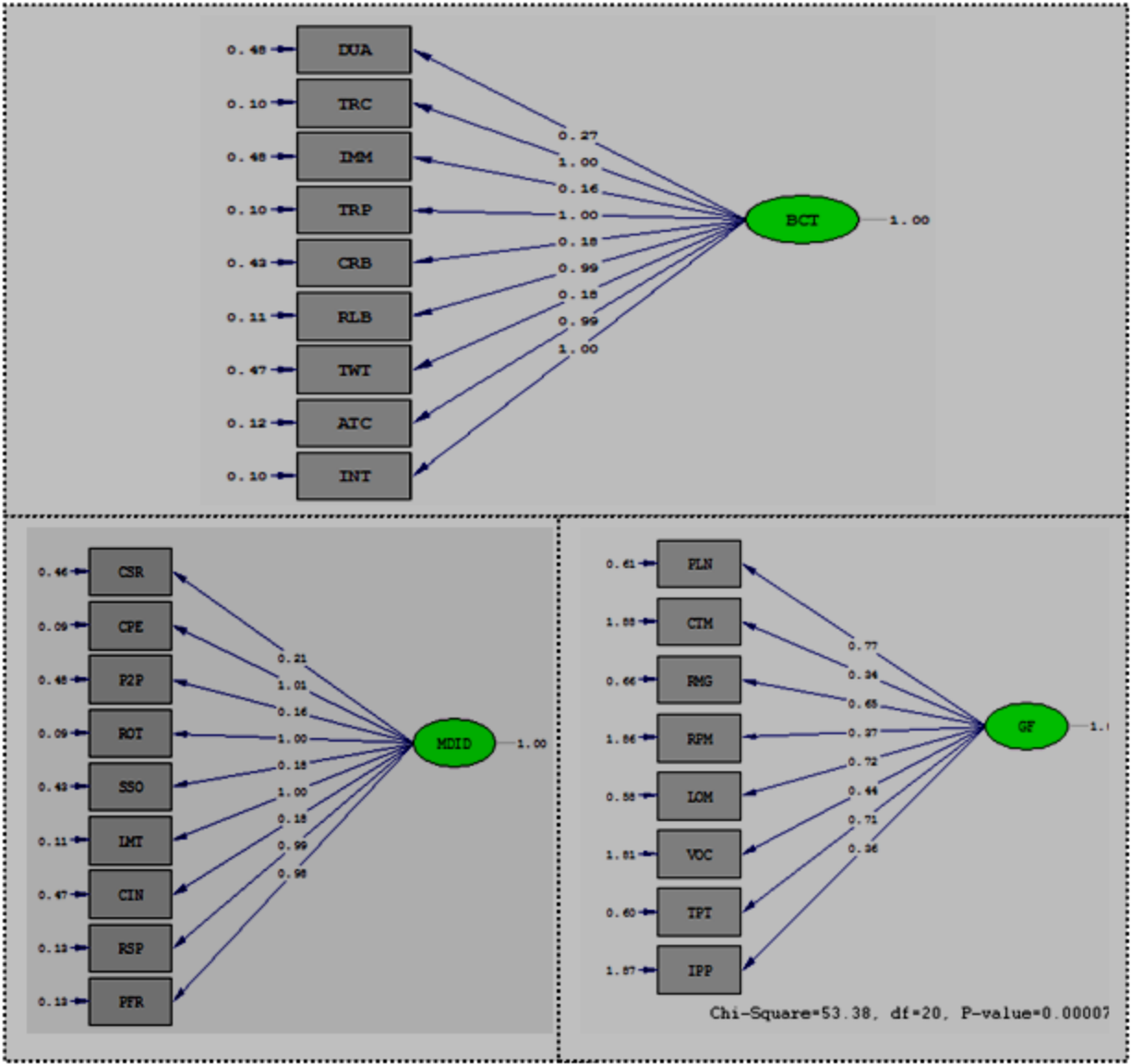

Figure 10: Model SEM Results

Items that loaded higher than 0.5 indicated that they were good measures of BCT, MDID and GF constructs and as such, they provided good convergent validity. Considering blockchain technology, TRC, TRP, RLB, ATC and INT had 1.00, 1.00, 0.99, 0.99 and 1.00 loadings respectively. As such, traceability, transparency, reliability, authenticity and integrity were the most significant features of the blockchain technology in e-learning. The other features including direct user access, immutability, credibility and trustworthy had loadings of 0.27, 0.26, 0.10 and 0.10 respectively. Although they had positive correlation coefficients, their values were below the threshold of 0.5 and were therefore dropped from the final model.

On the part of materials development and instructional design, CPE, ROT, LMT, RSP and PFR had loadings of 1.01, 1.00, 1.00, 0.99 and 0.98 respectively which were all above 0.5. Consequently, course purchase, ranking of tutors, learner motivation, research supervision and program fragmentation were regarded as significant activities that blockchain technology can help facilitate in e-learning materials development and instructional design. The other items including course sharing, peer to peer networking, single sign on and Constructivism instructions had loadings of 0.21, 0.16, 0.18, 0.18 respectively and although they had positive correlations coefficients, they were below the 0.5 threshold and were eliminated from the final model.

Regarding e-learning governance and finance, PLN, RMG, LOM and TPT had loadings of 0.77, 0.65, 0.72 and 0.71 respectively. As such, proof of learning, students records management, learning outcomes management and Tuition payment were the most crucial areas where blockchain could be applied in e-learning governance and finance. The rest of the items such as credentials and transcript management, reputation management, verification of credentials and IP protection loaded at 0.34, 0.37, 0.44 and 0.36 respectively. Although they had positive correlation coefficients, their values were below 0.5 and were therefore not included in the final model shown in Figure 11.

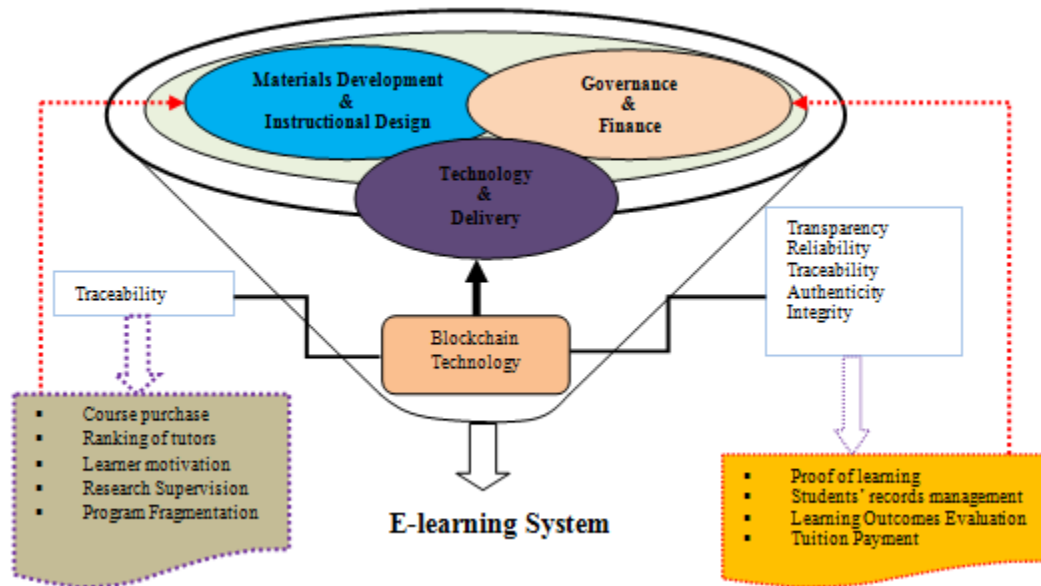

Figure 11: Attuned Extended Funnel Model for e-learning Implementation

Based on the results of this research, the blockchain features that are most applicable in e-learning environment include traceability, transparency, reliability, authenticity and integrity. Course purchase, ranking of tutors, learner motivation, research supervision and program fragmentation were found to positively impact e-learning materials development and instruction design. On the other hand, proof of learning, students records management, learning outcomes evaluation and tuition payment were established to be crucial in e-learning governance and finance.

IX. CONCLUSION AND FUTURE WORK

This paper sought to develop an e-learning model based on the blockchain technology. The literature review that was carried revealed a number of challenges with the current e-learning systems. The review also led to the identification of salient features of the blockchain technology that were used to extend the funnel e-learning model. Using structured equation modeling, some of the items that were originally hypothesized in the model were eliminated to arrive at the final attuned model. The developed model will be significant for learning institutions in the process of implementing or considering implementing e-learning. It gives insights on the areas where blockchain technology can leverage the e-learning systems as well as the salient features applicable in these areas. Future work in this area lies in the application of blockchain technology in extending and modeling other e-learning models that were elaborated in this study.

REFERENCES

- Aithal P., and Shubhrajyotsna A. (2015). An Innovative Education Model to realize Ideal Education System. *International Journal of scientific research and management*, Vol 3, Issue 3, pp. 2464-2469.
- Antonio R., Carles B., Linda C., and Jordi A. (2017). Blockchain In Education: Introduction and Critical Review of the State of the Art. *EDUTEC. Revista Electrónica de Tecnología Educativa*, No. 61, pp. 1-14.
- Carmen H. (2018). Understanding Blockchain Technology and How to Get Involved. In *Proceedings of the 14th International Scientific Conference eLearning and Software for Education*, Bucharest, pp. 1-9.
- Elda W., & Mary G. (2014). On safety and security in education: Pedagogical needs and fundamental rights of learners. *Educar*, Vol. 50, Issue 2, pp. 339-361.

- Fayed G., Jihad H., Alja'am M., & Hosam E. (2006). E-learning model based on semantic web technology. *International journal of computing & information sciences*, 4(2), pp. 63 – 71.
- Grech, A., & Camilleri, A. F. (2017). Blockchain in Education. Inamorato dos Santos, A. (ed.). *Joint Research Centre*.
- Guang C., Bing X., Manli L., and Nian S. (2018). Exploring blockchain technology and its potential applications for education. *Smart Learning Environments*. 5:1, pp.1-10.
- Hoy MB. (2017). An introduction to the Blockchain and its implications for libraries and medicine. *Med. Ref. Serv. Q.* 36(3), pp.273–279.
- Internet Society (2017). Internet Access and education: Key considerations for policy makers.
- Kennedy H., Robert O., and Elijah O. (2017). A model for evaluating e-learning systems quality in higher education in developing countries. *International Journal of Education and Development using Information and Communication Technology*, Vol. 13, Issue 2, pp. 185-204.
- Lee D. (Ed.) (2015) *Handbook of Digital Currency*, 1st ed., Elsevier.
- Mohamed J., and Oso W. (2014). Strategic Model of Implementing E-Learning. *International Journal of Scientific & Technology Research*, Volume 3, Issue 5.
- Moiz U., NazirA., and Amjad M. (2017). A Learner Model for Adaptable e-Learning. *International Journal of Advanced Computer Science and Applications*, Vol. 8, No. 6, pp. 139-147.
- Rehaf A.(2019). Analysis of Educational Quality, a Goal of Education for All Policy. *Canadian Center of Science and Education*, Vol. 9, No. 1.
- Sharples M., J Domingue J. (2016). The Blockchain and Kudos: A Distributed System for Educational Record, Reputation and Reward. *Adaptive and adaptable learning*, Springer, Cham, pp. 490–496.
- Skiba DJ. (2017). The potential of Blockchain in education and health care. *Nurs. Educ. Perspect.* 38(4), 220–221.
- Tschorsch F., & Scheuermann B. (2016). Bitcoin and beyond: A technical survey on decentralized digital currencies. *IEEE Commun. Surv. Tutorials* 18(3), 2084–2123.
- Vaishali S., & Dayanand S. (2015). Fundamentals of E-Learning Models: A Review. *IOSR Journal of Computer Engineering (IOSR-JCE)*, pp. 107-120.
- Venkatesh V. and Davis F.D. (2000). A Theoretical Extension of the Technology Acceptance Model: Four Longitudinal Field Studies. *Management Science*, 46, pp.186-204.
- Zheng, Z., Xie, S., Dai, H-N., Chen, X. and Wang, H. (2018). Blockchain challenges and opportunities: a survey', *Int. J. Web and Grid Services*, Vol. 14, No. 4, pp.352–375.