

REPAIR AND MAINTENANCE OF MOBILE CELL PHONES



Acknowledgements

This course was drafted at a Commonwealth of Learning workshop in Nairobi, Kenya in October 2013. The participants worked with Professor Fred Lockwood to test the rapid course development model.

We appreciate all the course authors who provided relevant information during the design and development of this course. In particular, we want to thank the following:

- | | |
|---------------------|--|
| 1. Kamau Charles | Masai Technical Training Institute |
| 2. Muasya Douglas | Coast Institute of Technology: Lead Author |
| 3. Mugure Tabitha | Thika Technical Training Institute |
| 4. Njoroge Stella | Masai Technical Training Institute |
| 5. Ochuma Johnstone | Kenya Institute of Curriculum Development |
| 6. Wanjala Antony | Coast Institute of Technology |

Instructional Design: Joan Mutero

Layout & Graphics: Anthony Okuku

Adviser: Dr Alison Mead Richardson



Commonwealth of Learning
© 2015 Commonwealth of Learning

This publication is made available under a Creative Commons Attribution-ShareAlike 4.0 Licence (international): <http://creativecommons.org/licenses/by-sa/4.0/>

Table of Contents

ABBREVIATIONS AND ACRONYMS	4
MOBILE CELL PHONE REPAIR AND MAINTENANCE	5
Introduction	5
TOPIC 1: TYPES OF MOBILE PHONES	6
What is a mobile phone?	6
Types of Mobile Phones.....	6
What is a form factor?	7
TOPIC 2: POTENTIAL HAZARDS ASSOCIATED WITH MOBILE PHONE REPAIR	9
What is a hazard?.....	9
TOPIC 3: PARTS OF A CONVENTIONAL MOBILE PHONE.....	11
TOPIC 4: MOBILE PHONE REPAIR TOOLS	13
Factors to Consider When Choosing Mobile Phone Repair tools.....	13
Tools for Mobile Phone Repair	13
TOPIC 5: DISASSEMBLING AND ASSEMBLING A MOBILE CELL PHONE.....	19
What is to disassemble?	19
What is to assemble?	19
Disassembling A Mobile Phone.....	20
Assembling a Mobile Phone.....	22
TOPIC 6: DIAGNOSING AND REPAIRING MOBILE PHONE FAULTS	23
Skills Needed to Diagnose and Repair a Mobile Phone	23
Mobile Phone Diagnosis	27
TOPIC 7: REPAIR OF COMMON MOBILE PHONE FAULTS	30
What is a fault?	30
Software Faults	42
GLOSSARY	45
REFERENCES	46
END OF COURSE SELF TEST	47

Abbreviations and Acronyms

3G:	3Rd Generation in Mobile Telephony
AC:	Alternate Current.
BGA:	Ball Grid Array
BSI:	Battery Status Indicator
CDMA:	Code Division Multiple Access
CPU:	Central Processing Unit
DCT:	Digital Core Technology
DC:	Direct Current
ESD:	Electro Static Discharge
FM:	Frequency Modulation
GSM:	Global System For Mobile phones
IC:	Integrated Circuit
IMEI:	The International Mobile Station Equipment Identity
LCD:	Liquid Crystal Device
LED:	Light Emitting Diode
MIC:	Microphone
PDA:	Personal Digital Assistance
PCB:	Printed Circuit Board
PFO:	Power Frequency Oscillator
RAM:	Random Access Memory
RTC:	Real Time Clock
SMD:	Surface Mount Device
SIM:	Subscriber identification module

Mobile Cell Phone Repair and Maintenance

Introduction

Welcome to this course on mobile cell phone repair and maintenance. A mobile cell phone is a hand held mobile device that can perform several communication functions. Mobile technology has become one of the fastest growing technologies in the world. Today people use mobile phones to stay in touch with friends and family, to share stories and photographs in social media, and to carry out financial transactions. Indeed, according to a World Bank policy research paper of 2012, 93% of Kenyans owned a mobile phone by the end of 2011.

This widespread ownership and use of mobile phones has created a need for professionals who can repair and service mobile phones. This course has been developed to address that need. The course targets people who would like to start and run a mobile repair and servicing business. By the end of this course you should be able to disassemble and assemble a mobile phone, diagnose the problem, service and repair a mobile phone with the help of proper tools and instruments.

This course is provided through distance learning and we trust that you will find the material useful both for studying and as future reference. We welcome your feedback on any issue relating to this course and wish you all the best. Happy Learning!

Learning Outcomes

Upon completion of this course you will be able to:

- Identify different types of mobile cell phones
- Recognise potential hazards in the repair of mobile cell phones
- Identify the parts of a mobile cell phone
- Use the correct hardware tools to repair mobile cell phones
- Assemble and disassemble a mobile cell phone
- Identify mobile cell phone faults and solve them.



Topic 1: _____

Types of Mobile Phones

Before we discuss the types of mobile phones, let us first look at the meaning of a mobile phone.

What is a mobile phone?

A mobile phone is a handheld device that allows you to make and receive telephone calls while you move around a wide geographical area. A mobile phone also supports several other functions, such as text messaging, email and internet access, photography, money transfer, banking, and so on.

Types of Mobile Phones

There are many different types of mobile phones available in the market. Which ones do you know? Take 2 minutes to think about it and then complete the following activity.



Activity 1:

Types of mobile phones (3 minutes)

List at least 4 types of mobile phones in the space provided below.

1. _____
2. _____
3. _____
4. _____

Well done! We believe your answer included the following types of mobile phones:

- Bar
- Brick
- Touch screen
- Flip
- Slider
- Swivel watch
- Taco
- Mixed flip and swivel

Well, there is no general rule used to classify mobile cell phones. However, in most cases they are classified on the basis of their form factor.

What is a form factor?

A **form factor** refers to the size, style, and shape of a mobile phone, as well as to the layout and position of the phone's major components. There are four major forms of mobile phones, namely:

- The bar phone,
- The touch screen phone
- The flip phone, and
- The slider phone.

Let us look at each form in further detail starting with the bar phone.

The Bar Phone

A bar phone is also known as the slab, block, or slate phone. It takes the shape of a cuboid, usually with rounded corners and/or edges. The name is derived from the rough resemblance to a candy bar in size and shape, see Figure 1 below.



Figure 1: A bar phone



Figure 2: Touch screen phone

The Touch screen Phone

A touch screen, or slate phone is a subset of the bar form. Like the tablet computer, a touchscreen phone has minimal buttons and instead relies on an electronic visual display known as a touch screen. It also has an onscreen QWERTY keyboard.

QWERTY refers to the arrangement of keys or buttons on an English computer keyboard.

Figure 2 shows a picture of a touchscreen phone.

The Flip Phone

A flip or clamshell phone consists of two or more sections that are connected by hinges, as shown in figure 3. The hinges allow the phone to flip open and fold to close in order to become more compact. When flipped open, the phone's speaker and microphone are placed closer to the operator's ear and mouth, thereby improving usability.



Figure 3: A flip phone



Figure 4: A slider phone

The Slider Phone

A slider or slide phone is composed of usually two, but sometimes more, sections that slide past each other on rails. It usually has a display segment which houses the speaker and screen, while the segment that slides in and out contains the keypad or keyboard. The sliding form factor allows the owner to take advantage of a full key board without sacrificing portability. Figure 4 shows a picture of a slider phone.

We hope you now understand the various types of mobile phones. Let us now look at the potential hazards that are associated the repair of a mobile phone.



Topic 2: _____

Potential Hazards Associated with Mobile Phone Repair

Your physical well being is important not only to yourself, but also to others. Therefore, as you embark on mobile phone repair, you should be aware of all the potential hazards and how to prevent them.

What is a hazard?

A hazard is anything that has the potential to cause harm to yourself or those around you. Before you learn the different types of hazards, let's start by defining some of the terms associated with hazards. Write down the meaning of the terms in the following activity.



Activity 2:

Meaning of terms associated with hazards (5minutes)

Write the meaning of the terms in the left hand column

Term	Meaning
Flammable	
Corrosive	
Toxic	
Fumes	

Compare your answers with those given at the end of this course.

Let us now look at the various types of hazards that you could encounter when repairing or maintaining a mobile phone?

There are quite a number of potential hazards that one can encounter when servicing or repairing a mobile phone. These are listed in Table 1 together with the preventive actions that you could take to avoid them.

Table 1: Potential hazards during mobile phone repair and their prevention

Hazard	Preventive Actions
Burns	Use of well insulated tools Use of gloves Keeping the soldering iron in the right place Unplugging equipment when not in use
Pricks by sharp objects	Appropriate storage of equipment Proper disposal of sharp objects Use of appropriate tools and equipment
Environmental pollution	Proper disposal of electronic wastes
Trailing electrical cables	Make sure electrical equipment is unplugged while not in use Safe storage of cables
Falls	Keep all tools, bins etc. in the right place

Having looked at potential hazards and how to protect ourselves during mobile phone repair, let us now consider the parts of a mobile phone.



Topic 3: _____

Parts of a Conventional Mobile Phone

A mobile phone has several parts or components. It is important for you to know the parts and understand their functions so that you can easily diagnose and solve problems. How many parts of a mobile phone do you know? Take a minute to think about it and then complete the following activity.



Activity 3:

Parts of a mobile phone. (5 minutes)

Name at least 4 parts of a mobile phone and their functions

Part	Function
Flammable	
Corrosive	
Toxic	
Fumes	

Compare your answers with what you read in the following section.

A conventional mobile phone is made up of many parts. Table 2 below explains the functions of the main parts.

Table 2: Parts of a mobile phone and their functions

Parts of a mobile cell phone	Functions
Keypad	Used for inputting or entering data into the phone. It is connected directly to the CPU
Ear piece	Converts the electric signal to a sound signal
Mouth piece	Transmits sound from one phone to another
Battery	Source of power supply to a mobile phone
Power switch	Switches the phone on and off

Power IC	It takes power from the battery and supplies to all other parts of a mobile phone
Oscillator	It creates frequency during outgoing calls
Screen or display	Displays data. It is connected to the CPU to receive following signals : LCD Data Signal, LCD Reset Signal, LCD WR Signal, LCD RD Signal, LCD FLM Signal, LCD HSYN Signal etc.
Flash IC	Stores the software and other programs installed in the mobile phone
Charging IC	Takes the current from the charger and charges the battery
CPU	Controls all sections of a mobile phone
Antenna	Receives and transmit radio frequencies and helps the phone to connect to the cellular network

Figure 5 below shows a printed circuit board (PCB) of a mobile phone showing the different internal parts. As you can see from this diagram the PCB is divided into two parts, the network section and the power section. The network section controls the incoming and outgoing phone calls, while the power section controls the memory and power related functions of the phone.

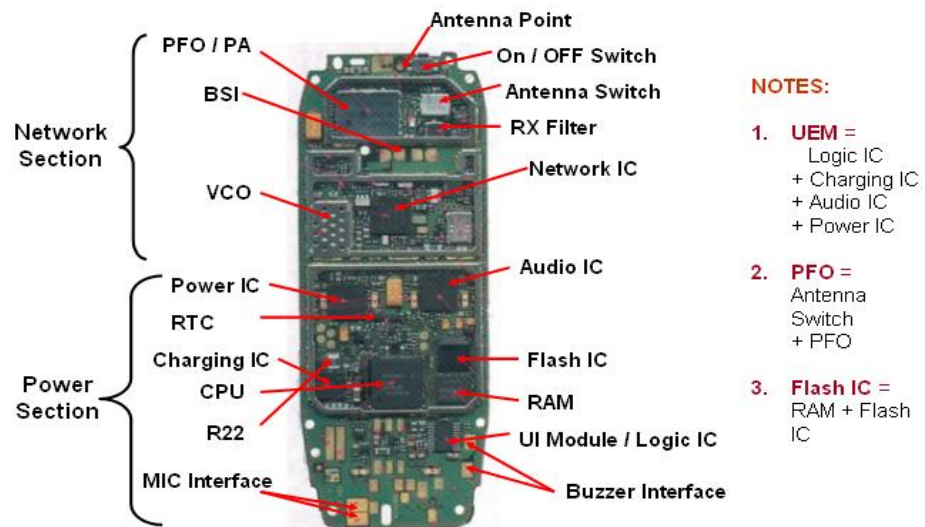

Figure 5: Parts of a mobile phone

We hope you now know the different parts of a mobile phone and their functions. Make sure that you learn them well and are able to locate them easily before you move on to the next section. Let us now look at the tools that you need to repair mobile phones.



Topic 4: _____

Mobile Phone Repair Tools

There are hundreds of tools for mobile phone repair available in the market. It is important to select the best tool that enables you to repair the phone easily and comfortably. Before you continue reading complete the following activity.



Activity 4:

Factors to consider when choosing mobile repair tools (5 minutes)

List three factors that you would you consider when choosing mobile phone repair tools?

1. _____
2. _____
3. _____

Now compare your factors with those we discuss in the following section.

Factors to Consider When Choosing Mobile Phone Repair tools

When selecting tools and equipment for repairing mobile cell phones, you should consider the following factors:

1. Cost
2. Brand
3. Quality/ Durability
4. Availability
5. Suitability

Tools for Mobile Phone Repair

Below are the tools and equipment needed for mobile phone repair.

1. **Soldering Iron:** Used to solder small components like capacitor, resistor, diode, transistor, regulator, speaker, microphone, display etc. A 50 watt soldering iron is good enough for most mobile phones repairing job.



Figure 6: Soldering iron

2. **PCB Holder / PCB Stand** (Printed Circuit Board): PCB is used to hold the PCB of a mobile phone while soldering or repairing. It holds the PCB very strongly and doesn't allow it to move thus helping in repairing.



Figure 7: PCB holder

3. **Solder Wire:** used to solder electronic components, ICs or jumpers. The composition of most solder wire is Tin / Lead in the ratio 60:40 or 63:37.



Figure 8: Solder wire

4. **Thinner or PCB Cleaner:** Thinner or PCB cleaner is used to clean the PCB of a mobile phone. The most common PCB cleaner used in mobile phone repairing is IPA or Isopropyl Alcohol. It is important to buy only good quality PCB cleaner as poor quality PCB cleaners can damage the system board.



Figure 9: Thinner or PCB cleaner

5. **Jumper Wire:** This is a thin laminated or coated copper wire used to jumper from one point to another on the track of a mobile phone during repair.



Figure 10: Jumper wire

6. **Point Cutter:** It is used for cutting



Figure 11: Point cutter

7. **Blade Cutter:** This is used to remove lamination from jumper wire. It can also be used for several other purposes.



Figure 12: Blade cutter

8. **Nose Cutter:** this is used for cutting.



Figure 13: Nose Cutter

9. **Precision Screwdriver:** It is used to remove and tighten screws while assembling and disassembling a mobile phone. Precision screwdrivers of sizes T4, T5, T6 and forehead are good for most mobile repairing job.



Figure 14: Precision screwdriver

10. **Tweezers:** These are needed to hold electronic components, ICs, jumper wire etc. while soldering and Desoldering.



Figure 15: Tweezers

11. **Brush:** These are used for cleaning the PCB of a mobile phone when it is being repaired. It is important to buy only ESD-Safe cleaning brushes.



Figure 16: Brushes

12. **Multimeter:** an electronic measuring device that has the ability to measure voltage, current and resistance. It is used to test and check the readings of various parts and components of a mobile phone.



Figure 17: Digital Multimeter (Source: commons.wikipedia.org)

13. **Hot Air Blower:** It is also called SMD (Surface Mount Device) rework system and SMD repair system. It has control to regulate or manage temperature and flow of hot air. Always buy a good quality ESD-Safe hot air blower.



Figure 18: Hot air blower

14. **Battery Booster:** It is used to boost the power of battery of a mobile phone.



Figure 19: Battery booster

15. **Screwdriver Kit:** It has several screwdrivers of different shapes and sizes to disassemble and assemble a mobile phone.



Figure 20: Assorted screwdrivers

16. **Microscope:** It is used to see a magnified view of PCB or electronic components. These are available in different zoom options. Many microscopes can also be connected to a computer or a monitor.



Figure 21: Microscope

17. **Test JIG Box:** This device is used to diagnose and find fault or problem in a mobile phone. It helps the mobile phone to work and function normally outside its case. This helps to test and check voltage and other test points on the PCB. In simple words it helps the mobile phone to work without battery.



Figure 22: Test JIG box

18. **Battery Tester:** This device is used to test and analyze the status or condition of the battery of a mobile cell phone.



Figure 23: Battery tester

19. **Cleaning Sponge:** this is used to clean the tip of soldering iron while soldering.



Figure 24: Cleaning sponge

20. **Solder Paste:** The solder paste is a low melting metal alloy used to join together metal work pieces. It has a lower melting point than the metal work pieces.



Figure 25: Solder paste

21. **LCD Tester:** Used to check whether the LCD screen of a mobile phone is faulty or not.

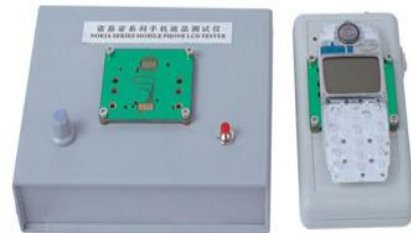

Figure 26: LCD tester

You now know the main tools that are used to repair a mobile phone. In the next topic we shall discuss how to disassemble and assemble a mobile phone.



Topic 5: _____

Disassembling and Assembling a Mobile Cell Phone

What is to disassemble?

To disassemble is to take something apart or to break it down into pieces.

What is to assemble?

To assemble is to fit together all the separate pieces in order to form one whole.

Before you continue reading, complete the following activity.



Activity 5:

Disassembling a mobile phone (5 minutes).

What steps would you follow when disassembling a mobile phone? Write them down in the space provided below

1. _____
2. _____
3. _____
4. _____
5. _____
6. _____
7. _____

Compare your answer with what you read in the following section.

Disassembling a Mobile Phone

The following are the steps that you should take when disassembling a mobile phone:

1. Switch off the phone
2. Remove the battery cover
3. Remove the battery, SIM card memory card (if any)
4. Remove all the screws from the phone
5. Lift back the cover with the help of a flat screwdriver
6. Remove the strips (buzzer strip, display, camera, volume and speaker button strips)
7. Remove the antennae wire from the outside
8. Remove the motherboard and vibrator.

To successfully disassemble a phone, you need to understand the various internal sections of a mobile phone and how they are connected to the CPU. Let us look at that next.

Internal Parts of a Mobile Phone

Table 3 below outlines the main sections and how they are connected.

Table 3: Internal parts of a mobile phone

Internal Section	Connections
SIM card section	SIM Card Interface section is directly connected with the CPU in most mobile cell phones. If there is no power supply in a mobile phone then the SIM section is connected with the CPU through the Power IC.
Memory card section	In most phones the micro SD card holder is connected through a 8-pin socket. The memory card section is found inside the CPU
Ear Speaker Section	In modern mobile cell phones which have a separate ear speaker, the speaker is directly connected to the CPU. It receives sound via signals directly from the CPU or from the audio section inbuilt within the CPU. In some mobile phones, these sound signals are received via coil / resistance. Some mobile phones have audio IC in the audio section, while others have audio amplifier.
Speaker/Ringer Section	The ringer, buzzer or speaker in most mobile phones are connected to the audio amplifier IC to obtain loud sound. The amplifier IC amplifies the sound or audio signal received from the CPU of the audio section.

Key Backlight Section	LED Lights are connected according to the parallel circuit in the key backlight section. Anode ends of all the LEDs are connected to each other and all the cathode ends to each other. 3 to 3.3 V is supplied for the functioning of these key LED Lights.
LCD Backlight Section	LCD Backlight in mobile cell phones is made according to the series circuit. A Boost Voltage Generator section is built for the supply of high voltage (10 to 18V) for the functioning of the LCD LED. Boost coil, Boost Volt Driver IC, Rectifier Diode are present in this section.
Vibrator Motor Section	Positive power supply is given to this section directly from the positive end of the battery. Negative power supply is given through a NPN transistor or from the ground of any circuit.
Network Section	Antenna, External Antenna Socket, RX-Band Pass Filter, RF Crystal, FEM, PFO, TX-Band Pass Filter, RF IC, CPU are connected in the Network Section.
Battery Charging Section	Charger and system interface connector is made together in most modern mobile cell phones. Regulator section is made separately for the battery charging section. In some mobile phones, the battery charging section is made inside the Power IC.
FM Radio Section	FM Radio Driver IC, FM Antenna, Signal and Supply Components are made in the FM Radio Section.
Bluetooth Section	Bluetooth Antenna, Bluetooth RF Signal Filter, Bluetooth Driver IC, Supply and Signal Components are found in this section. The Bluetooth section functions like the Network Section. The RF-CLK signal is given to the Bluetooth driver IC during signal processing.
Hands free (Earphone) Section:	The hands free jack, hands free MIC, speaker signal component and hands free audio amplifier are present in this section. Hands free symbol is displayed after connecting the Hands free jack.

Assembling a Mobile Phone

The following are the steps that you should take when assembling a mobile phone:

1. Fix the vibrator strips of speaker and volume button
2. Fix the motherboard
3. Connect the antenna with wire
4. Place the camera and connect it
5. Place the buzzer
6. Put the camera cover
7. Make sure that the LCD is working before you place the screen
8. Put battery and battery cover

So far you have learnt about the hazards of mobile phone repair, the parts of a mobile phone, the tools to use and how to assemble and disassemble a mobile phone. Now let us look at how to diagnose and repair a mobile phone.



Topic 6: _____

Diagnosing and Repairing Mobile Phone Faults

The correct diagnosis of mobile cell phone faults is the key to successful and cost effective repair of the phone. Let us start by looking at the skills that you need to have to be able to diagnose and repair a mobile phone.

Skills Needed to Diagnose and Repair a Mobile Phone

Before you can diagnose and repair a phone, there are some skills that you need to learn. These skills are:

- Soldering
- Desoldering
- Testing using a multimeter
- Jumper setting

Let us briefly discuss each skill in turn.

Soldering

Soldering is a process in which two or more metal items are joined together by melting and flowing a filler metal into the joint. The filler metal has a relatively lower melting point.



Figure 27: Picture showing A technician Soldering

Steps In Soldering

1. Prepare the following materials:
 - Soldering Iron,
 - Solder paste
 - Long Nose Pliers,
 - PCB holder,
 - Electronic Components (Resistors, Diode etc.)
2. Plug and pre-heat the soldering iron.
3. Heat both items at the same time by applying the soldering iron to the copper pad and the component lead.
4. Continue heating and apply a few millimeters of solder. Remove the iron and allow the solder joint to cool naturally.
5. It only takes a second or two to make the perfect joint, which should appear shiny.

Desoldering

Desoldering is the removal of solder and components from a printed circuit board for troubleshooting, repair, replacement, and salvage.

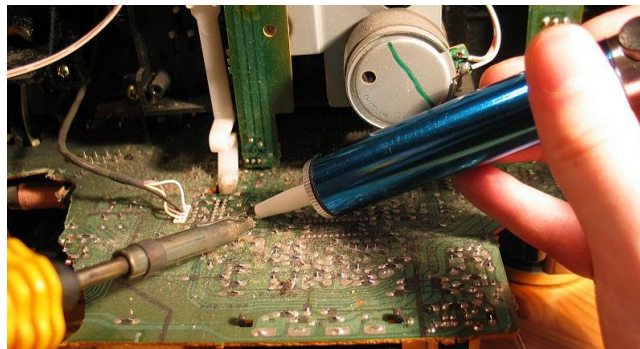

Figure 28: Desoldering

Steps in desoldering

1. Use a solder wick (finely braided copper) to wick away excess solder from a de-soldered connection.
2. Apply the solder wick and use the soldering iron to the de-soldered connection. The solder wick will draw the excess solder off the PCB pad.

Testing a phone using a multimeter

We hope you still remember that a multimeter is a device that is used to measure the voltage, current and resistance of various components of a mobile phone. Figure 29 below shows the various parts of a multimeter



Figure 29: Parts of a multimeter

We shall now discuss how to measure resistance, voltage and current using a multimeter.

a) Measuring Resistance

To measure resistance follow these steps:

1. Plug your red and black probes into the appropriate sockets on your multimeter.
2. Choose the appropriate resistance measurement setting on your millimeter's
3. Hold the probes against the resistor.
4. Check the resistor value on the display.



Figure 30: Using a Multimeter

Take Note: Always turn off the power supply to your circuit before measuring resistance.

b) Measuring voltage

Testing for proper supply voltage is usually the first step when troubleshooting a circuit. To measure voltage you should follow these steps:

1. Select V~ (ac) or V (dc), as desired.
2. Plug the black test probe into the COM input jack. Plug the red test probe into the V input jack.
3. If the DMM has a manual range only, select the highest range so as not to overload the input.

4. Touch the circuit with the tips of the probes
5. Read the number in the display window and take note of the unit of measurement.

c) Measuring Current

1. Turn off power to the circuit.
2. Cut or unsolder the circuit, creating a place where the meter probes can be inserted.
3. Select A~ (ac) or A (dc) as desired.
4. Plug the black test probe into the COM input jack. Plug the red test probe into the amp or milliamp input jack, depending on the expected value of the reading.
5. Connect the probe tips to the circuit across the break so that all current will flow through the DMM (a series connection).
6. Turn the circuit power back on.

Jumper setting

Jumpering means to temporarily complete a circuit or to bypass a break in a circuit by making a connection from one point to another.

A good conductor wire is used to make a jumper which by-passes the components and passes on a signal or supply line for further uses.

When wire is used as a jumper, it must have some special specifications as required. These jumper wires can mainly be of two types i.e. insulated and non-insulated. In the mobile phone insulated wires are used for jumpers. The length of a jumper depends on the two points connected in between.

Why do Jumpering

While repairing mobile phones, we find that certain faulty components are very difficult to get from the market. To repair such mobile phones the only immediate option is the use of jumpers. By use of jumpers we will bypass the faulty components specifically.

How to Jumper

1. Disassemble mobile phone and place it on a PCB holder.
2. Using a multimeter, check track and find the fault or the missing track that need jumper.
3. Apply liquid soldering flux to the points where you need to solder jumper wire.
4. Cut jumper wire to desired length and remove its lamination using blade cutter.
5. Hold one end of the jumper wire and solder it to one point of the faulty circuit track. Use a good quality tweezers to hold the wire and good quality of soldering iron and solder wire to solder.
6. Now hold the other end of the jumper wire and solder to the other point of the track
7. Using a multimeter check the jumper.

The Figure 31 Below shows jumper settings in of the jumpers may look like on your motherboard. In this example, the jumper is the white block covering two of the three gold pins. Also, next to the pins is a silkscreen description of what the pins do, in this case when pins 1-2 are jumped the computer is operating normal, when 2-3 are jumped it is set into configuration mode, and when open the computer will be in recovery mode.

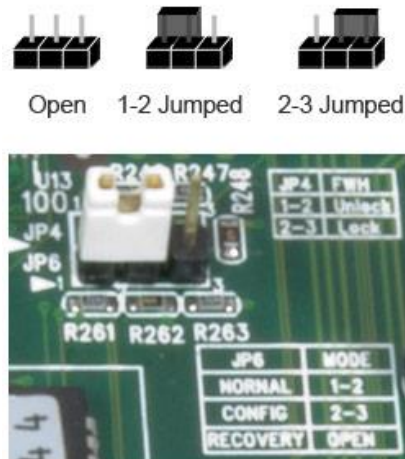

Figure 31: Jumper Setting

You now know the skills that you need in order to diagnose and repair a mobile phone. Let us now learn how to diagnose and repair mobile phones.

Mobile Phone Diagnosis

There are two methods that you can use to find out faulty or damaged components in a mobile phone. These are:

- The cold testing method
- The hot testing method

The Cold Testing Method:

Cold testing is when we use a multimeter to check the value of resistance at the time of repairing a fault in a mobile phone. During cold testing do not power the phone from any equipment. Use the diode range and beep sound from the multimeter to find fault in the mobile phone. During cold testing, you should connect the RED probe of the multimeter to the ground of the mobile phone PCB, and use the BLACK probe to touch the testing points of the mobile phone. During the fault-finding and repairing process of each part, component or section, you should receive the following correct values:

1. Ear Phone Connector Tip (+, -): .500 to .700
2. Loud Speaker / Ringer Connector Tip (+,-): .300 to .600
3. Battery Connector Tip (+): .400 to .500

4. Battery Connector Tip (Sense): above .800
5. Display Connector Supply Pins: .250 to .400
6. Display Connector Signal Pins: .500 to .800
7. Camera Connector Supply Pins: .250 to .400
8. Camera Connector Signal Pins: .600 to .900
9. Key Tip (Row and Column): .400 to .800
10. Charger Connector Tip: .600 to .700
11. Vibrator Motor Connector: .40 to .500
12. Power ON / OFF Switch Point (+): .600 to .900
13. MIC Connector Tip (Analog MIC) (+,-): .700 to .900
14. Battery Charging Out Point (+,-): .300 to .400
15. SIM Card Connector Pin 1 (VSim): .500 to .700
16. SIM Card Connector Pin 2,3,6: .400 to .800
17. SIM Card Connector Pin 4 (GND): .00 (Beep)
18. Micro SD Card Connector Pin 4: .500 to .600
19. Micro Card Connector Pin 6 (GND): .00 (Beep)
20. Micro Card Connector Pin 1,2,3,5,7,8: .600 to .800
21. RTC: .400 to .500
22. Data RX and TX Pins: .600 to .700

Hot Testing:

The hot testing method is adopted when the fault cannot be found or when the cell phone cannot be repaired using the cold testing method. In this method, the VOLTAGE of the damaged part or component is checked. The fault is found by powering the mobile phone with a battery which has a DC power supply. Once you power the phone, you should select the DCV (DC Volt) range of the Multimeter. Then you should connect the BLACK probe of the Multimeter to the ground of the phone's PCB and ensure the RED Probe touches the Testing Points. During hot testing, the voltage of different part or sections should be as follows (all values in Volt):

1. Ear Phone Connector Tip (+, -) when working: .0 to 2.5
 2. Loud Speaker / Ringer Connector Tip (+,-) when working: .0 to 2.5
 3. Battery Connector Tip (+): 3.7
 4. Display Connector Supply Pins: 1.8 to 2.9
 5. Display Connector Signal Pins when working: .0 to 1.8
 6. Camera Connector Supply Pins: 1.8 to 2.9
 7. Camera Connector Signal Pins when working: .0 to 1.8
 8. Key Tip (Row and Column) One Side: 1.8 to 2.8
 9. Charger Connector Tip: 5 to 6
 10. Vibrator Motor Connector Tip when Working: 1.9 to 3.6
 11. Power ON / OFF Switch Point (+): 3 to 3.6
 12. MIC Connector Tip (Analog MIC) (+,-): 1.8 to 3.0
-

13. Battery Charging Out Point (+,-): 3.7 to 4.2
14. SIM Card Connector Pin 1 (VSim) when SIM Connected: 1.8 to 3.0
15. SIM Card Connector Pin 2,3,6 when working: 0 to 2.8
16. Micro SD Card Connector Pin: 2.8
17. Micro Card Connector Pin 1,2,3,5,7,8: 0 to 2.8
18. Data RX and TX Pins: 1.8 to 2.8



Activity 6:

Mobile phone diagnosis (8 minutes).

The following statements describe either the cold testing or hot testing methods used for diagnosing mobile phone problems. Write the correct diagnosis method against the statement that best describes it.

Description of diagnosis method	Name of Diagnosis method
1. Checks the value of resistance using a multimeter to diagnose a problem	
2. Checks the voltage of damaged part by giving power to the mobile phone using a batter of DC power.	
3. The phone is not powered during testing	
4. Fault is found by powering the mobile phone with a battery	

Compare your answer with what you read in the following section.

You now know how to diagnose a fault in a mobile phone using the hot and cold testing method. In the next section we shall learn about the common mobile phone faults.



Topic 7: _____

Repair of Common Mobile Phone Faults

What is a fault?

A fault is a defect (a failure in a circuit) or an electronic device.

What causes faults or failures in mobile phones?

Failures can be caused by any of the following:

- excess temperature,
- excess current or voltage,
- ionizing radiation,
- mechanical shock,
- stress or impact,
- contamination,
- mechanical stress,
- short circuits,
- imperfect connections,
- poor insulation or wiring caused by grounding.

There are three types of mobile phone faults:

- (i) Hardware faults: occur due to hardware malfunctioning
- (ii) Software faults: occur due to problems with software
- (iii) Settings faults: occur due to wrong/invalid settings

Let us discuss each type of faults and how they can be repaired.

Hardware Faults

There are many hardware faults that can occur in a mobile phone, but in this section we shall discuss the following:

- a) Battery charging faults/problems
- b) Mobile phone battery problem (faults)
- c) Network not working problem
- d) Overheating problem
- e) Sound faults
- f) Ear piece, ringer and microphone problem
- g) Display problems
- h) Lighting or LED problems
- i) Touchscreen problems

- j) Keypad problems
- k) SIM faults
- l) WiFi problem and internet connectivity problems

a) Battery Charging Faults/Problems

Battery charging faults manifest in a number of ways:

- The battery is not charge at all,
- There is a sign of battery charging but the battery does not get charged.
- When the charger is inserted, it shows 'Not Charging'.
- When the charger is connected it shows 'Bad Connecting Charging'.
- When the charger is inserted the mobile phone gets hot.

Solutions to Battery charging faults

1. Change the charger and check. The voltage must be between 5 and 7 Volts.
2. Clean, resold or change the charger Connector.
3. If the phone shows "FALSE CHARGING" then use a 3.6 Volt Zenor Diode and do direct charging as shown in Figure 32.
4. If the problem is not solved then change the battery and check again
5. Check the voltage of the battery connector using a Multimeter. The voltage should be between 1.5 and 3.7 Volts.
6. If there is no voltage in the connector check the track of the charging section. Refer to the diagram of the particular model of the mobile phone.
7. If the problem still persists, check the fuse, coil and regulator one by one and change the faulty part.
8. If the problem is still not solved then heat or change the charging IC.
9. Finally heat, re-ball or change the Power IC.

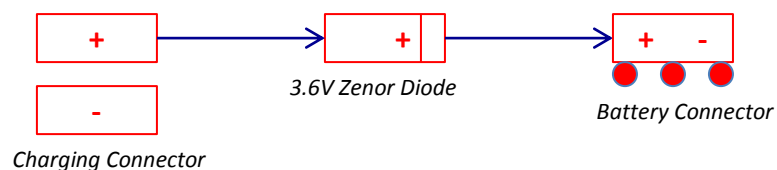

Figure 32: Charging the battery of a phone using a zenordiode

b) Mobile Phone Battery problem

A mobile cell phone can have any of the following battery problems:

- Low Battery
- Battery Drains Fast
- Battery Backup Low,
- Battery Not charging

Solutions to Battery faults

1. Check the battery connector and charger plug to see if there is any problem.
2. Check if there is any dust or corrosion in the connector or any broken pin. Clean the points using IPA or cleaning swabs.
3. Check the Interface Connector to see if there is any dust. If there is dust clean or replace the interface connector.
4. If the battery problem is not solved then upgrade the software or operating system to latest version
5. If the problem is still not solved then check the Mobile Phone PBA current consumption.
6. Check for any short circuit.
7. If there is serious problem at the board level then it is better to replace the whole Logic Board of the Mobile Cell Phone.

c) Network Not Working Problem

The common issues related to this problem include the following:

- There is no network in the mobile phone
- There is less or weak network signal
- Sometimes there is a signal and sometimes there is no network signal.

Solutions to Network fault

1. Manually search for the network. If the 'no network problem' persists, then there is a problem with the Antenna Switch. Repair or replace it.
2. If the network resumes after manual search but the home network cannot be selected, then there is a problem with the PFO. Repair or change the PFO.
3. If the Network gets disconnected during phone calls then you should repair or change the Network IC.
4. Clean the antenna tips and point.
5. If the network problem persists, heat or change the 26MHz Crystal Oscillator.
6. If the problem is still not solved then heat or change the Antenna Switch. You can also jumper if the Antenna Switch is not available.
7. Heat, Change or Jumper the PFO if the problem still persists.
8. Heat, re-ball or change the Network IC.
9. Heat, re-ball or change the Power IC.
10. Heat, re-ball or change the CPU.



Take Note: If the problem is not solved by hardware interventions, then reload the PM File in the mobile phone using the software box.

d) Network Signal and Call Drop Problem

If a mobile phone is having network problems and dropping calls, then you should use the following steps to solve it:

1. Check the SIM Card. Insert the SIM card in other mobile phone and see if the network problem or the 'call drop' problem is still there.
2. Alternatively, try to insert another SIM card inside the mobile phone that has the network problem.
3. If the problem is caused by the SIM card, then you should change or replace it.
4. If the problem is still not resolved then upgrade the operating system to the latest version. You can also rewrite the IMEI Number of the mobile cell phone.
5. If the problem is not solved then you may have to change the mobile phone.

e). Mobile Phone Overheating

A mobile phone may overheat either inside or on the body. To solve this problem you should proceed as follows:

1. Check if the mobile phone overheats when a particular application is running or if the overheating happens all the time.
2. Upgrade the mobile phone software operating system to the latest version. This may solve the overheating problem.
3. Smartphone's overheat if too many applications are running at the same time. Close all the applications and try to run 1 application at a time
4. If overheating persists, then there is some internal hardware problem. Change the PCB or Logic Board to solve the heating problem.

f). Sound Faults

We shall consider the following types of sound faults:

- Earpiece or ear speaker problem
- Mobile phone speaker problem
- Ringer problem
- Vibration problem
- Microphone problem

i). Earpiece or Ear Speaker Problem

The Earpiece or speaker is the electronic component or part that helps us to listen to sound during a phone call. It is controlled by Audio IC or Power IC (UEM). See Figure 27 for a picture of an ear speaker.



Figure 33: Ear speaker

The common problems associated with the ear speaker are:

- No sound during phone call
- Low sound during phone call
- Sound has interruptions.

How to Solve Earpiece or Speaker Fault

1. Check the speaker volume during a phone call.
2. If speaker volume is fine, then check the earpiece by keeping the multimeter in buzzer mode. The value must be between 25~35 Ohm. If the value is not between 25~35 Ohm then change the earpiece.
3. If the problem is not solved then check the Circuit Track of the earpiece section. Do jumper wherever required.
4. If the problem persists heat, reball or change the UEM/Audio IC.
5. If the problem is still not solved then heat, reball or change the CPU.



Take Note: If the sound is low or not clear during a phone call, then you should change the speaker.

ii. Ringer Problem

A Ringer is any type of electronic component that rings or plays a loud sound. It is also called the I.H.F Speaker, buzzer, melody, etc. Figure 28 shows a picture of a ringer.

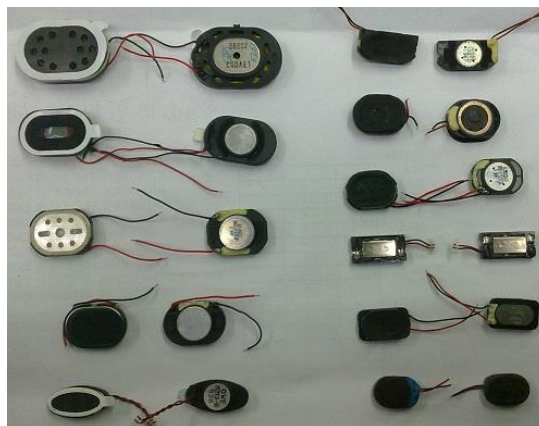

Figure 34: Cell phone ringers

The following are the types of problems associated with the ringer:

- Ringer not working
- Low sound from the Ringer
- Sound coming from Ringer but with interruption
- Sound not clear

How to Solve Ringer Faults

1. Check the ringer settings in the mobile phone. Check Ringer volume and silent mode. Adjust or change the volume and /or mode if required.
2. If the problem is not solved then open the mobile phone and clean the ringer point and ringer connector.
3. If the problem is not solved then check the ringer by keeping the multimeter in buzzer mode. The value must be between 8 ~ 10 Ohm. If the value is not between 8~10 Ohm then change the Ringer.
4. If the problem is not solved then check the track of ringer section. Do jumper wherever required.
5. If the problem is not solved then check the Ringer IC. Heat or change the IC.
6. If the problem is not solved then heat, reball or change the UEM / Logic IC.
7. If the problem is still not solved then heat, reball or change the CPU.



Take Note:

- If there is less sound from the Ringer then change the Ringer.
- If the problem is not solved then heat or change the Ringer IC.

iii. Vibration Problem

The vibrator is an electronic device that generates vibrations. It is controlled by the Logic IC or Power IC.

The common types of faults associated with the vibrator are:

- Vibrator not working
- Vibration has an interruption
- Vibration Hangs.

How to solve Mobile Vibrator faults

1. Check the Vibrator settings in the mobile phone. Check if the Vibrator is ON or OFF.
2. If the problem is not solved then open the mobile cell phone and clean the vibrator tips and connector.
3. If the problem is not solved then check the vibrator with the multimeter in Buzzer Mode. The value must be between 8~16 Ohm. If the value is not between 8~16 Ohm then change the Vibrator or Motor.
4. If the problem is not solved then check the track of the vibrator section. Do jumper wherever required.

5. If the problem is not solved then heat, reball or change the UEM/Logic IC /Power IC.
6. If the problem is still not solved then heat, reball or change the CPU.

iv. Microphone Problem

The Microphone is an electronic component that helps to transmit sound during phone call. A microphone is controlled by Audio IC or Power IC (UEM).

The common types of problems associated with the microphone are:

- Low sound during phone call
- Sound has interruption
- Change in sound.

How to Solve Microphone Fault

1. Check the Microphone settings.

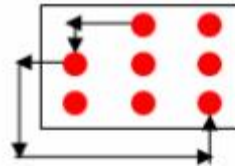

Figure 35: Jumper Setting For Microphone

2. If all the settings are normal, then check and clean the Microphone tips and connector.
3. If the problem is not solved then check the Microphone with the multimeter in Buzzer Mode. The value must be between 600~1800 Ohm. If the value is not in between that range, then change the Microphone. Note that only one side will give a value.
4. If the problem is not solved then check the track of the Microphone section. Do Jumper wherever required.
5. If the problem is not solved then heat or change the Microphone IC.
6. If the problem is not solved then heat, reball, or change the UEM / Audio IC /Power IC.
7. If the problem is still not solved then heat, reball or change the CPU.

g) Display Not Working

This is the part that displays information in a mobile phone. It is controlled by the CPU. In some cell phones there is an Interface IC called the Display IC situated between the Display and the CPU.

The following are the common types of problems associated with the display:

- Display is blank.
- Display not working properly.
- Only half the display works.
- White display.

- Display is upside down.
- Display is broken.
- When the mobile phone is switched ON, the Logo appears and then the display disappears

How to Solve Display Faults in a Mobile Cell Phone

1. Clean the display tips and display connector.
2. Resold the display connector
3. Change the display
4. Check the display Track.
5. Resold or change the display IC.
6. Heat, reball or change the CPU.



Take Note:

- In the slider mobile phone handset, the display problem is mainly due to a faulty display track. Change the track to solve the problem.
- If the Display is upside down, broken or it displays information on half the screen then you should change the display
- If the Display is white even after changing it, then you should reload the software.

h) Mobile Light or LED Problem and Solution

The LED is the electronic component that generates light in the mobile phone. There are 2 types of connections in the light section of a mobile phone:

- Series Connection;
- Parallel Connection.

Figure 36 shows a diagram of series and parallel connections.

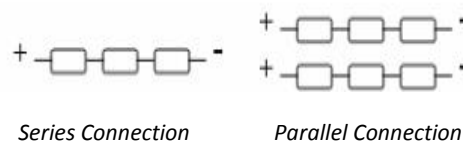

Figure 36: Diagram Showing Series and Parallel Connections

The common symptoms of LED problems are:

- No Light.
- Light only in the Keypad or Display.
- Some lights not working

How to Solve a LED problem

1. Check the light settings.
2. If the settings are normal then resold all the LED.
3. If the problem is not solved then change the display or the screen.
4. Next check all the LEDs with the multimeter on Buzzer mode. If the LED is good then it will glow. If the LED is faulty then it will not glow.
5. Change the LED or jumper if required.
6. If the problem is not solved then check the Track of the light section of the PCB and jumper if required.
7. Next check the Boosting Coil and change if required.
8. If the problem is not solved then heat or change the Light IC.
9. If the problem is still not solved then heat, reball or change the Power IC.

i) Phone Touch Screen (PDA) fault

A Touch Screen (PDA) is an electronic component that allows you to input data or control your mobile phone by touching the screen. It normally has 4 Points namely:

- (+),
- (-),
- (RX),
- (TX).

The touch screen is normally controlled by the CPU. In some mobile phones there is an Interface IC called PDA IC or Screen Touch IC.

The following are the faults associated with the Touch Screen

- Touch Screen not working.
- Only half the Touch Screen works.
- When one key is pressed another key works.

How to Solve Touch Screen (PDA) Faults

1. Check the settings if the mobile phone has both a keypad and a touch screen.
2. Clean and resold the PDA Pins and PDA connector.
3. Change the PDA.
4. Check the Track of the PDA section and Jumper if required.
5. Heat or change the PDA IC
6. Heat, reball or change the CPU



Take Note:

- If the PDA problem is not solved by hardware solutions, then reload the software to solve the problem.
- Any PDA of the same size will fit in any mobile phone. Any one of the 5 Jumper Settings shown in figure 37 below will work:

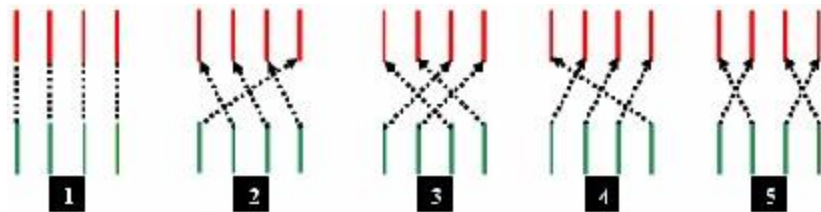

5 Types of PDA jumper solution

Figure 37: Jumper settings for PDA

(h) Keypad Problems

The keypad enables you to enter data, such as, phone numbers and names in your mobile phone.

The main types of problems associated with the keypad are:

- Some keys not working.
- Keys need more pressure to work.
- When a key is pressed it works continuously.
- When one key is pressed, some other key works
- When one key is pressed, some other key works simultaneously.

How to Solve a Keypad Faults

1. Check the facial of the keypad.
2. Clean the keypad and keypad points shown in Figure 38 below.

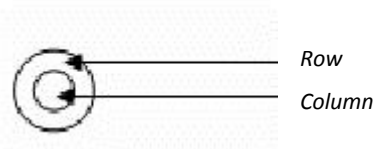

Figure 38: Keypads and keypad points

3. Using the multimeter in Buzzer Mode and check the Row and Column of the Keypad. If there is a beeping sound then the keypad is working.
4. If there is no improvement, heat or change the Keypad IC or the Interface IC.
5. If still no change, heat, reball or change the CPU.



Take Note:

- If you press a key and it takes a long time to work, then you should reload the software to solve this problem.
- In all Nokia mobile phones, if none or only a few keys are working, then you should change the keypad IC to solve the problem.

(i) Mobile Phone SIM faults

A Subscriber Identify Module (SIM) card is an integrated circuit that securely stores information about the number of the cell phone line, password, and information related to your local network service. It has a unique serial number.

The following are the common problems associated with the SIM card:

- SIM is inserted but still there is a message saying “Insert SIM”.
- The mobile phone goes OFFLINE when the SIM card is inserted.
- The SIM works for sometime and then stops working.
- There is a message that says “Invalid SIM”

How to Solve SIM Card Fault

1. Check settings and see if the mobile phone is in Flight Mode. If it is in “Flight Mode” then change it to Normal mode.
2. Clean the SIM Card Tips and SIM Connector.
3. If the problem is not solved then change the SIM card and check.
4. If the problem still persists then change the SIM connector.
5. If you still do not find a solution to the problem, check the Track of the SIM section.
6. If the problem is still not solved then heat or change the SIM IC.
7. Finally, if there is no change, heat, reball or change the Power IC.



Take Note:

- Check if the IMEI number is good or is corrupt by dialling the number, *#06#. If the response reads as follows:
35826*****220 OR *****???
*****000? OR *****?
Then the IMEI number is corrupt.
- Reload the IMEI Number to solve the SIM Problem.
- Check the BSI Point of the battery. The middle Pin is the BSI point. Change the battery and check. If the display shows “Not Charging” and at the same time there is a SIM card problem, then it could be either due to a BSI Problem of the Battery or the BSI Track of the PCB.
- If you need to change the SIM IC and the SIM IC is not available then you can do Jumper. The function of the SIM IC is just to complete the circuit.

(j) Mobile Wi-Fi Wireless Internet Connection Problem:

This problem may present in the following ways:

- No internet
- Low Wi-Fi signal
- Wi-Fi cannot be enabled

How to Solve Wi-Fi problem

1. Enable Wi-Fi and check if it is working or not. Make sure you are connected to a wireless network. Make sure the password is correct.
2. If the Wi-Fi cannot be enabled and you are not able to use or access the internet, then there could be problem with the mobile phone PCB and you may have to replace it.
3. If the Wi-Fi can be enabled then there is no problem with the PCB. Just upgrade the software of the mobile phone to the latest version.

You now know the common hardware problems found in mobile cell phones. Next let us discuss the software problems and how to solve them.

Software Faults

A software is a set of programs, routines and symbolic language that control the functions of hardware and directs its operations.

The common software problems are:

- Display problems
- No signal message
- Dead phone set
- Phone on test mode
Phone not charging
- Phone has message to contact service provider
- Phone hangs, goes off, freezes or has slow processing

How to solve these problem:

1. Check the downloaded applications and note when the problem happened.
2. Note whether the problem is happening when a certain application is running.
3. Remove the application that is causing the problem
4. If the problem is still not solved then reset the factory settings of the mobile phone and update the software.

You have now come to the end of our topic on common mobile phone problems or faults. Before you move on, do the following activity to evaluate your understanding of this section.



Activity 7:

Common mobile phone faults and their solutions. (4 minutes).

Match the cell phone problems or fault in Column A with the correct solutions in Column B.

Column A	Column B
Cell Phone Problem	Solutions
Display not working	Clean and resolder the PDA tips
Faulty ear piece	Check the speaker volume
Phone is overheating	Close all the applications and run one at a time
Network problem	Change the charger
Vibrator is not working	Repair the antenna
Phone dropping calls	Rewrite the IMEI number of the phone
Touch screen problem	Check if phone is in vibrate mode
Battery problem	Resold the display connector

Compare your answers with those given at the end of this course.

Congratulations! You have come to the end of our course on mobile phone repair and maintenance. Let us review what you have learnt.

Summary

We started this study by identifying the different types of mobile phones. We saw that they include the bar, touch screen, and flip phones to name just a few. We also considered the key hazards and safety precautions associated with the mobile phone repair and servicing. The hazards included: burns, pricks, environmental pollution and falls. We also discussed the factors to consider when selecting tools for mobile phone repair. These factors included cost, suitability and quality of the tools. In addition, we examined the tools used for mobile phone repair, such as solder wire, PCB holder, jump wire, and screw driver. Next we determined the steps that you should follow to disassemble and assemble a mobile phone and how to diagnose mobile phone faults. Lastly, we discussed common hardware and software faults and how to solve them.

Answers to Learning Activities

Activity 2: Meaning of terms associated with hazards

Write the meaning of the terms in the left hand column

Term	Meaning
Flammable	Easily set on fire or capable of burning quickly
Corrosive	Causing damage or gradual destruction of metal or skin by chemical action
Toxic	Poisonous
Fumes	Smoke, vapour or gas that may be dangerous or irritating to smell

Activity 6: Mobile Phone diagnosis

The following statements either describe the cold testing or hot testing methods for diagnosing mobile phone problems. Write the correct diagnosis method against the statement that best describes it.

Description of diagnosis method	Name of Diagnosis method
1 Checks the value of resistance using a multimeter to diagnose a problem	Cold Testing
2 Checks the voltage of damaged part	Hot testing
3 The phone is not powered during testing	Cold testing
4 Fault is found by powering the mobile phone with a battery	Hot testing

Activity 7: Common mobile phone faults and their solutions.

Match the cell phone problems or fault in Column A with the solutions in Column B

Column A	Column B
Cell Phone Problem	Solutions
Display not working	<i>Resolder the display connector</i>
Faulty ear piece	<i>Check the speaker volume</i>
Phone is overheating	<i>Close all the open applications and open one at a time</i>
Network problem	<i>Repair the antennae switch</i>
Vibrator is not working	<i>Check if vibrator is turned off</i>
Phone dropping calls	<i>Rewrite the IMEI number of the phone</i>
Touch screen problem	<i>Clear and resold the PDA tips and connectors</i>
Battery problem	<i>Change the charger</i>

Glossary

Hazard	Anything that has potential to cause harm to yourself and all those around you.
A fault	A defect (a failure in a circuit) of an electronic component
Switch	An electrical component that can break an electrical circuit, thereby interrupting the current or diverting it from one conductor to another.
Jumper	Jumpers are small blocks on a circuit board with two or more pins emerging from them.
Boot	To start or restart a mobile device.
Bluetooth	A wireless technology standard for exchanging data over short distances
Driver	A program that operates or controls a particular type of device.
Motherboard	The main board that holds electronic components of the system,(CPU) and memory, and provides connectors for other peripherals.
Diagnose	To identify the nature of a problem by examining the symptoms.
Soldering	A process in which two or more metal items are joined together by melting and flowing a filler metal (solder) into the joint. The filler metal has a lower melting point than the adjoining metal.
Soldering Iron	A tool normally used for applying heat to two or more adjoining metal parts in order for the solder to melt and bind them securely and conductively.
Solder	A fusible metal alloy with a melting point or melting range of 90 to 450 degree Celsius, used in a process called soldering where it is melted to join metallic surfaces.
Disassemble	To take something apart; or to disconnect the pieces of something.
Assemble	To bring things together for a common purpose.
Voltage	The difference in charge between two points or amount of potential energy between two points Voltage is measured in volts which uses the symbol V.
Current	How much electricity is flowing through the circuit. A current is measured in amperes. The symbol for amperes or amps in short is described by the symbol A.
Resistance	How difficult it is for electricity to flow through something. Resistance is measured in ohms.
Reballing	A process where the defective chip is lifted off and repaired by applying lead based solder on the chip and placing it back on the board or replacing the component with a new one while also applying lead based solder on it before soldering it back on the circuit board.

References

Wikipedia. 2010. *Form factor (mobile phones)*. [ONLINE] Available at: https://en.wikipedia.org/wiki/Form_factor_%28mobile_phones%29. [Accessed 04 July 15].

Shashilata D. 2012. *mobile-phone-repairing-tools-equipment-tools-to-repair-mobile-cell-phone.html*. [ONLINE] Available at: <http://www.mobilecellphonerepairing.com>. [Accessed 05 February 15].

Service manuals, Schematics . 2010. *Service manuals, Schematics > Mobile Phones > Nokia*. [ONLINE] Available at: <http://www.s-manuals.com/phone/nokia>. [Accessed 05 February 15].

Phone Repair Tutorials.2011. *Free CellPhone Repair Tutorials* [ONLINE] Available at: <http://cellphonerepairtutorials.blogspot.com>. [Accessed 05 February 15].

computer hope.2011. *What is a Jumper?*. [ONLINE] Available at: <http://www.computerhope.com/jargon/j/jumper.htm>. [Accessed 06 March 15].

allgsmtips. 2013. *What Are The Parts Inside A Cell Phone*. [ONLINE] Available at: <http://allgsmtips.com/>. [Accessed 06 February 15].

End of Course Self Test _____

Hardware Faults

1. Name any five types of hardware faults
 - (i)
 - (ii)
 - (iii)
 - (iv)
 - (v)

2. List four types of battery faults.
 - (i)
 - (ii)
 - (iii)
 - (iv)

3. List three types of signal faults /Network faults
 - (i)
 - (ii)
 - (iii)

4. Identify four types of sound faults?
 - (i)
 - (ii)
 - (iii)
 - (iv)

5. State three types of display faults
 - (i)
 - (ii)
 - (iii)

6. State any five types of keypad faults
 - (i)
 - (ii)
 - (iii)
 - (iv)
 - (v)

7. State any six types of SIM faults

- (i)
- (ii)
- (iii)
- (iv)
- (v)
- (vi)

8. Name any six Micro SD Card /MMC faults

- (i)
- (ii)
- (iii)
- (iv)
- (v)
- (vi)

9. Complete the table below by writing the possible causes of the phone faults in the left hand column.

No:	Phone problem	Possible cause
1.	Unable to send SMS	
2.	Only incoming call	
3.	Security code	
4.	No signal	
5.	SIM locked message	
6.	Contact service provider	

Software Faults

10. List any five phone software faults.

- (i)
- (ii)
- (iii)
- (iv)
- (v)

Answers: _____

Hardware faults

- 1.
- 2.
- 3.
- 4.
- 5.
- 6.
- 7.
- 8.
- 9.

No:	Phone problem	Possible cause
1.	Unable to send SMS	No service centre number
2.	Only incoming call	Call barring enabled
3.	Security code	Wrong security code
4.	No signal	Service provider not selected
5.	SIM locked message	Wrong PIN/ SIM lock code
6.	Contact service provider	Sim card blocked by service provider

Software faults

- i Display
- ii No signal
- iii Dead set
- iv Test mode
- v Not charging
- vi Contact service provider
- vii Hanging
- viii Auto restart
- ix White screen
- x Ring out on its own
- xi Select options on its own
- xii Run extremely low
- xiii Auto off